

WHEEL TOP

 **WHEELTOP**

/2025/

兰溪轮峰车料有限公司  
地址:浙江省兰溪市城郊西路22号  
LANXI WHEEL TOP CYCLE INDUSTRIES, LTD.  
ADD: 22 WEST CHENGJIAO ROAD, LANXI, ZHEJIANG, CHINA  
TEL: +86(579)89022978 89022983  
FAX: 86(579)88230111 88230678  
E-mail: sales@wheeltop.com

地址:天津市武清区汉沽港镇自行车王国祥园17号道  
TIANJIN WHEEL TOP CYCLE INDUSTRIES, LTD.  
ADD: NO.17 XIANGYUAN ROAD BICYCLE KINGDOM PARK, CHAGUGANG TOWN, WUQING DISTRICT, TIANJIN, CHINA  
TEL: +86(22)59696335  
FAX: 86(22)59696337  
E-mail: elaine.song@wheeltop.com

兰溪江诚车业有限公司  
地址:浙江省金华市兰溪市香溪镇香溪镇工业园豹山路11号  
LANXI KOSEI BICYCLE ACCESSORIES CO LTD.  
ADD: 11, BAOSHAN ROAD, XIANGXI INDUSTRIAL ESTATE LANXI ZHEJIANG CHINA  
TEL: +86(579)88400038  
FAX: +86(579)88400388  
http:www.kosei-q.com

兰溪智行云运动科技有限公司  
地址:浙江省兰溪市创业大道13  
LANXI SUPER SMART CYCLING CLOUD SPORTS SCIENCE AND TECHNOLOGY CO., LTD  
ADD: NO. 13, CHUANGYE STREET, LANXI, ZHEJIANG  
TEL: +86(579)83881076  
FAX: +86(579)83888356

http:www.wheeltop.com

SINCE 1951

兰溪轮峰车料有限公司

LANXI WHEELTOP CYCLE INDUSTRIES, LTD.



A close-up photograph of several interlocking bicycle gears, showing their teeth and central hubs. The gears are dark in color, possibly black or dark grey, and are set against a light background. The lighting highlights the texture and precision of the metal components.

企业简介 | Introduction of enterprice



SINCE 1951

兰溪轮峰车料有限公司

LANXI WHEEL TOP CYCLE INDUSTRIES,LTD

Continuous innovation,continuous improvement,open source and reduce expendoture.

People-orie-nted,customer satisf-action,the pursuit of excellence.

Create high-precision transmission products, guide the market trend,provide high-quality services,meet the needs of customers,and make bicycle riding lighter,riding life happier and better.



# 目录 | Contents

01

01 2-PCS

23 ROAD

27 MTB

37 CITY & FOLDING

59 KIDS

02

DERAILLEUR

99 前拨/转把

100 后拨/指拨

03

101 飞轮

103 无线电子变速系统

BELT PULLEY

04

NEW GB

05

06



# 产品索引目录

## 2-PCS/一体式

NAME/名称	COMPATIBILITY/速别	GEAR/齿数	CHAINLINE/链线	PAGE/页码
SAGE13-C1-WA42	11/12	40T,42T	49.5	01
SAGE13-C2-WA46	12	46/30T	47	01
SAGE13-C2-WA48	10/11	48/31T	47	02
SAGE13-C2-WA50	12	50/34T	44.5	02
CR16-Z1-YB36	11/12/13	36T	49	03
CR16-Z1-YA34	11/12/13	32T,34T	48	03
CR16-Z2-YA36	11/12	36/26T	48.5	04
SR11-A1-YB36	11	36T	49.5	04
SR13-A2-YA36	11/12	36/26T	48	05
SR13-A2-Y538	11/12	38/28T	48	05
SAGE11-C2-YA50	11	50/34T	43.5	07
SAGE11-C2-Y550	8/9/10	50/34T	43.5	07
GA-04-C	/	53T	45	08
CR11-X1-YA34	12	30T,32T,34T	48,49.5	08
CR11-Z1-YA38	12	32T,34T,36T,38T	49.5,52	09
CR12-M1-Y536	12	34T,36T	49.5,52,55	09
SR11-A1-YA38	11	32T,34T,36T,38T,40T,42T	49.5,52	10
SR11-A1-Y538	11	32T,34T,36T,38T	49.5,52	10
SR12-B2-YA36	10/11	36/22T	48.5	11
SR12-B2-YA38	10/11	38/24T	48.5	11
SR13-A1-YA32	11	32T,34T,36T,38T	49.5,52	12
SR13-A1-YA38	11/12	32T,34T,36T,38T,40T,42T	49.5,52	12
SR13-G1-YA34	11	30T,32T,34T	49.5,52	13
SR13-A1-YB32	10/11	32T,34T,36T,38T	49.5	13
SR13-B2-YA36	10/11	36/22T	48.5	14
SR13-B2-YA38	10/11	38/24T	48.5	14
SR13-G2-Y540	10	40/28T	49.5	15
SR13-A3-YA42	10	42/32/24T	50	15
SR13-G3-YA40	10	40/30/22T	50	16
SR13-A3-Y540	9	44/32/22T	50	16
SR13-G3-Y540	10	40/30/22T	50	17
SR13-B3-Y542	9	40/30/22T	50	17

## ROAD/公路车

NAME/名称	COMPATIBILITY/速别	GEAR/齿数	CHAINLINE/链线	PAGE/页码
HIGHKU-7WB	9	53/39T	44	23
HIGHKU-75B	9	53/39T	45	23
HIGHKU-75BB	10	53/39T	44.3	23
HIGHKU+7WB-CD	9	50/34T	46	24
ARROW-430	9	53/39T	44.3	24
ARROW-420	9	53/39T	44.3	24

## ROAD/公路车

NAME/名称	COMPATIBILITY/速别	GEAR/齿数	CHAINLINE/链线	PAGE/页码
ARROW-110	8/9	50/34T	46	25
ARROW-320(G)	8	52/42T	44	25
ARROW-320	8	52/42T	44	25
ARROW-330	8	52/42/30T	45	25
DHH110B-CE	8	50/34T	45	26
D55110-CE2WUR	8/9	50/34T	45.5	26
SR-11-D	/	32T,34T,36T,38T防脱链齿形	49.5	26
SR-11-E	/	32T,34T,36T,38T防脱链齿形	49.5	26

## MTB/山地车

NAME/名称	COMPATIBILITY/速别	GEAR/齿数	CHAINLINE/链线	PAGE/页码
TAIKLONG-AB450A	8	48/38/28T	48.5	27
TCXC2L-HF1	9/10	40/30/22T	48.5	27
TCXC2E-HF1	9/10	40/30/22T	48.5	27
TAIKLONG-HT4505	9	44/32/22T	48.5	28
TCXC2L-HT1	10	42/32/24T	50	28
TCXC2E-HU1	10	42/32/24T	50	28
DCXC2E-HF2	10	40/28T	50	29
DCXC2D-HX1	8	48/36T	48.5	29
HAWK-HX1	10	48/38/28T 42/32/22T 42/34/24T	47.5	29
HAWK-HG1	9	44/32/22T	48.5	30
HAWK-DX(A)	7/8	48/38/28T	47.5	30
TCRF4-VA	7/8	48/38/28T	48	30
DCRX1-SMA(G4XD)	8	46/30T	49	31
DCRX1-SMA(G4FE)(LFE46)	8	46/30T	49	31
DCRX1-SMA(G4FE)(LFE36)	8	36/22T	49	31
TCRF4-SMA(G4XD)	7/8	48/38/28T	48	31
TCRF4-SMA(G4RB)(A4G4)	7/8	48/38/28T	48	32
TCRF4-SMA(G4RB)(LFG)	7/8	48/38/28T	48	32
TCSH4-SMA	7/8	42/34/24T	48.7	32
TCRF4-SMF(G4RB)(LFG)	7/8	48/38/28T	48	32
TCRF4-MGC	7/8	48/38/28T	48	33
TCSH4-SMF	7/8	42/34/24T	48.7	33
TCSH4-SMA	7/8	42/34/24T	48.7	33
TCSH-SMA	7/8	42/34/24T	48.7	34
TCXH-SMA(RE)	9	44/32/22T	48.7	34
TCXH-SMA(AF)	7/8	42/32/22T	48.7	34
TCSH4-HE3	7/8	42/34/24T	48.7	35
TCSH4-SH	7/8	42/34/24T	48.7	35
TCSH4-SMA	7/8	42/34/24T	48.7	35
TCSH4-CFPG	7/8	42/34/24T	48	35



# 产品索引目录

## MTB/山地车

NAME/名称	COMPATIBILITY/速别	GEAR/齿数	CHAINLINE/链线	PAGE/页码
TCSH4-CFPF	7/8	42/34/24T	48	36
TCSH4-CFPY	7/8	42/34/24T	48.5	36
TCSH4-CFPG	7/8	48/38/28T	48.3	36
TCSH4-MZ(B)	7/8	42/34/24T	48.7	36

## CITY&FOLDING/城市车 折叠车

NAME/名称	COMPATIBILITY/速别	GEAR/齿数	CHAINLINE/链线	PAGE/页码
LANXI-52AA	/	3/32"52T	45	37
LANXI-45AA	/	3/32"45T	45	37
LANXI-42AA	/	3/32"42T	45	37
SOB5B130Y-BY2WR(29GA-48)	/	1/8"44T 48T	45	38
SOB5B130Y-BY2WR	/	1/8"46T 52T	45	38
SPB5B110S-CE2WR	/	3/32"50T	45	38
SOB5B110S-CE2WR	/	46T	45	38
 SCKG12-SAGE13A1-D	/	3/32"40T	45	39
SXB5B130W-RD2W	/	3/32"45T	45	39
SXB5A-MAXI	/	3/32"46T 48T	46.5	39
SXB5B130W-RD2W	/	3/32"42T 44T 46T 48T	46.5	39
RAMBLF-EX44A	/	3/32"44T	45.5	40
SOB5B114C-MAXI	/	1/8"44T 48T	46.5	40
SXB5B-MGC	/	3/32"52T	45	40
SPB5B-MT	/	3/32"52T	45	40
SPB5B-MX4	/	3/32"44T 46T	45	41
SPB5B-ME	/	3/32"48T	45	41
SPB4B-MGB	/	3/32"46T	45	41
TOP-A44	/	3/32"44T	45	41
TOP-S046	/	1/8"46T	45	42
TOP-B48	/	3/32"36T 46T 48T	45	42
TOP-46PP	/	3/32"46T	45	42
TOP-GK5H	/	1/8"48T	45	42
TOP-GK5F	/	3/32"48T	45	43
SPB4B-ME	/	3/32"48T	45	43
SIC2F-10P-MGB	/	3/32"42T	45	43
SOF8H-MTT	/	1/8"48T	48	44
SPB5B-MT	/	3/32"52T	45	44
SXB4B-YBT	/	3/32"44T	45	44
SPB4B-MT	/	3/32"46T	45	44
DIAMOND-ICK	/	3/32"38T 42T 44T	45	45
DIAMOND-ICZ	/	3/32"38T 42T 44T	45	45
DIAMOND-ICBPP	/	3/32"38T	45	45
DIAMOND-ICF	/	3/32"38T 42T 44T	45	45

## CITY&FOLDING/城市车 折叠车

NAME/名称	COMPATIBILITY/速别	GEAR/齿数	CHAINLINE/链线	PAGE/页码
DIAMOND-ICM	/	3/32"38T 42T	45	46
DIAMOND-ICB	/	3/32"38T 42T 44T 46T	45	46
DIAMOND-ICT	/	3/32"38T 42T	45	46
DIAMOND-100B	/	3/32"38T	45	46
TOP-X40	/	3/32"40T 42T 44T 46T	45	47
TOP-GK3Y	/	1/8"38T	45	47
TOP-G3CK	/	3/32"33T 36T	45	47
SIC2F30-MGB	/	1/8"36T	45	48
SOD3H-MT	/	1/8"33T 36T	45	48
SOD3H-YBT	/	1/8"33T 36T	45	48
TOP-Y425	/	3/32"42T	45	49
TOP-G5KP	/	3/32"36T	45	49
TOP-G5KJ	/	3/32"36T	45	49
TOP-GK3H	/	3/32"36T	45	50
TOP-P36	/	3/32"36T	45	50
TOP-H36	/	3/32"36T	45	50
TOP-K36	/	3/32"36T 40T	45	51
TOP-M36	/	3/32"36T	45	51
TOP-G5KE	/	3/32"36T	45	51
TOP-Q36	/	3/32"36T 40T	45	52
TOP-I36	/	3/32"36T	45	52
TOP-N36	/	3/32"36T 40T	45	52
SKD5F-MS	/	3/32"36T	45	53
SIC2F10P-ME	/	3/32"36T 40T	45	53
TOP-PD	/	3/32"36T	45	53
SRF4F-YBT	/	3/32"44T	45	53
SKD5F-YBT	/	3/32"36T	45	54
SKD5F-YBT-1	/	3/32"36T	45	54
SKF3F-YBT	/	3/32"36T	45	54
SPB4B-Y	/	3/32"40T	45	54
SPD4H-YBT	/	3/32"36T 38T 40T	45	55
SPF5H-YBT	/	3/32"32T 33T	45	55
SPD4H-YBT	/	3/32"36T	45	55
SPE4H-RFS	/	3/32"42T	45	56
TOP-32T	/	1/8"30T 31T 32T 33T 34T 36T 38T 40T	45	56
SOF5H-MS	/	1/8"28T 30T 31T 32T 33T 34T 36T 38T 48T	45	56
SOF5H-YBT	/	1/8"30T 31T 32T 33T 34T 36T 38T 40T	45	57
SPB4B-MZ	/	3/32"42T	45	57
TOP-MT	/	3/32"38T 42T	45	57
TOP-MZ	/	3/32"36T 40T	45	58
Y-32T	/	1/8"30T 31T 32T 33T 34T 36T 38T 40T	45	58



# 产品索引目录

## KIDS/儿童车

NAME/名称	COMPATIBILITY/速别	GEAR/齿数	CHAINLINE/链线	PAGE/页码
SXB4BL-WM	/	3/32"28T 32T	45	59
SXB4BL-MS	/	3/32"28T 32T	45	59
SPB4B-MS	/	3/32"28T	45	59
SPF5H-MS	/	3/32"32T	45	59
SPF5H-SH	/	3/32"32T	45	60
TOP-MB	/	3/32"38T 42T 44T	45	60
SPF5H-MZ	/	3/32"24T 28T	45	60
SOF0H-Y	/	1/8"28T 32T	45	60
SPF4H-KT	/	3/32"28T 32T	45	61
 PB4BB55-MC	/	28/32T	45	61
TOP-Y	/	1/8"24T 28T	45	61

## E-BIKE/电动车

NAME/名称	PAGE/页码
MIVICE	67
BAFABG	68
ANANDR	69
VINKA	71
BOSCH	72
BROSE	73
TSE	73
MOLTEN	73
SPIDER/链接爪	74
CHAINRINGS/链轮	79
铝罩	83
常用配置	85

## BELT PULLY/皮带轮

NAME/名称	PAGE/页码
前皮带轮	87
皮带轮后飞	88
后飞	89
皮带	90
皮带张紧器调整配件	91
曲柄	92

## NEW GB/新国标电动车

NAME/名称	PAGE/页码
新国标电动车	95
飞轮	95
中轴	96
链条	96
曲柄	97
链轮	92

## DERAILLEUR/机械变速器

NAME/名称	PAGE/页码
前拨	99
转把	99
后拨	100
指拨	100

## EDS/无线电子变速

NAME/名称	PAGE/页码
飞轮	103
无线电子变速系统	109



CRANK SET

E-BIKE

BELT PULLY

NEW GB

DERAILLEUR

EDS





2-PCS

一体式







2-PCS/一体式



NEW

CKG30-SAGE30

CRANK LENGTH	曲柄长度	170
GEAR	齿数	50/34
CRANK MATERI	曲柄材质	AL-6061-T6
GEAR FINISH	曲柄涂层	HBK
GEAR PROCESS	齿片	5MM ALLOY CNC DETAIL
GEAR FINISH	齿片涂层	HBK
OUTSIDE BEARING	外挂轴套	24MM
COAMPATIBLTY	变速兼容	11 12 13S
CHAINLINE	链条中心线	44.5MM
PCD	螺丝分布直径	110MM
Q-FACTOR	曲柄后下叉距离	155M
WEIGHT	重量	950g



NEW

CKG10-SAGE10

CRANK LENGTH	曲柄长度	170	175
GEAR	齿数	50/34	
CRANK MATERIAL	曲柄材质	AL-6061-T6	
GEAR FINISH	曲柄涂层	HBK	
GEAR PROCESS	齿片	5MM ALLOY CNC DETAIL	
GEAR FINISH	齿片涂层	HBK	
OUTSIDE BEARING	外挂轴套	24MM	
COAMPATIBLTY	变速兼容	9 10 11S	
CHAINLINE	链条中心线	44.5MM	
PCD	螺丝分布直径	110MM	
Q-FACTOR	曲柄后下叉距离	155M	
WEIGHT	重量	888g	



NEW

CKG30-SAGE30K

CRANK LENGTH	曲柄长度	170
GEAR	齿数	50/34
CRANK MATERI	曲柄材质	AL-6061-T6
GEAR FINISH	曲柄涂层	HBK
GEAR PROCESS	齿片	5MM ALLOY CNC DETAIL
GEAR FINISH	齿片涂层	HBK
OUTSIDE BEARING	外挂轴套	24MM
COAMPATIBLTY	变速兼容	11 12 13S
CHAINLINE	链条中心线	44.5MM
PCD	螺丝分布直径	110MM
Q-FACTOR	曲柄后下叉距离	155M
WEIGHT	质量	950G



NEW

CKG10-SAGE10K

CRANK LENGTH	曲柄长度	170	175
GEAR	齿数	50/34	
CRANK MATERIAL	曲柄材质	AL-6061-T6	
GEAR FINISH	曲柄涂层	HBK	
GEAR PROCESS	齿片	5MM ALLOY CNC DETAIL	
GEAR FINISH	齿片涂层	HBK	
OUTSIDE BEARING	外挂轴套	24MM	
COAMPATIBLTY	变速兼容	9 10 11S	
CHAINLINE	链条中心线	44.5MM	
PCD	螺丝分布直径	110MM	
Q-FACTOR	曲柄后下叉距离	155M	
WEIGHT	重量	888g	

一体式  
公路车  
山地车  
城市车  
折叠车  
儿童车





# 2-PCS/一体式



## SAGE B-C1-WA42 (CKG12-SAGE13A1)

CRANK LENGTH	曲柄长度	170,172.5,175mm
GEAR	齿数	40,42T
CRANK MATERIAL	曲柄材质	AL-6061-T6
CRANK FINISH	曲柄涂层	HBK
CHAINRING	齿片	4mm Alloy CNC Detail
CHAINRING FINISH	齿片涂层	HBK
OUTSIDE BEARING	外挂轴套	24mm
COMPATIBILITY	变速兼容	11/12S
CHAINLINE	链条中心线	49.5mm
PCD	螺丝分布直径	110mm
Q-FACTOR	曲柄后下叉距离	151mm
WEIGHT	重量	750g



## SAGE B-C2-WA48 (CKG12-SAGE13A2)

CRANK LENGTH	曲柄长度	170,172.5,175mm
GEAR	齿数	48/31T
CRANK MATERIAL	曲柄材质	AL-6061-T6
CRANK FINISH	曲柄涂层	HBK
INNER CHAINRING	内圈齿片	2mm Alloy CNC Detail
CHAINRING FINISH	齿片涂层	HBK
OUTER CHAINRING	外圈齿片	3mm Alloy CNC Detail
CHAINRING FINISH	齿片涂层	HBK
OUTSIDE BEARING	外挂轴套	24mm
COMPATIBILITY	变速兼容	10/11S
CHAINLINE	链条中心线	47mm
PCD	螺丝分布直径	110mm
Q-FACTOR	曲柄后下叉距离	151mm
WEIGHT	重量	860g



## SAGE B-C2-WA46 (CKG12-SAGE13A2)

CRANK LENGTH	曲柄长度	170,172.5,175mm
GEAR	齿数	46/30T
CRANK MATERIAL	曲柄材质	AL-6061-T6
CRANK FINISH	曲柄涂层	HBK
INNER CHAINRING	内圈齿片	2mm Alloy CNC Detail
CHAINRING FINISH	齿片涂层	HBK
OUTER CHAINRING	外圈齿片	3mm Alloy CNC Detail
CHAINRING FINISH	齿片涂层	HBK
OUTSIDE BEARING	外挂轴套	24mm
COMPATIBILITY	变速兼容	12S
CHAINLINE	链条中心线	47mm
PCD	螺丝分布直径	110mm
Q-FACTOR	曲柄后下叉距离	151mm
WEIGHT	重量	840g



## SAGE B-C2-WA50 (CKG12-SAGE13A2)

CRANK LENGTH	曲柄长度	170,172.5,175mm
GEAR	齿数	50/34T
CRANK MATERIAL	曲柄材质	AL-6061-T6
CRANK FINISH	曲柄涂层	HBK
INNER CHAINRING	内圈齿片	2mm Alloy CNC Detail
CHAINRING FINISH	齿片涂层	HBK
OUTER CHAINRING	外圈齿片	3mm Alloy CNC Detail
CHAINRING FINISH	齿片涂层	HBK
OUTSIDE BEARING	外挂轴套	24mm
COMPATIBILITY	变速兼容	12S
CHAINLINE	链条中心线	44.5mm
PCD	螺丝分布直径	110mm
Q-FACTOR	曲柄后下叉距离	154mm
WEIGHT	重量	890g

一体式  
公路车  
山地车  
城市车  
折叠车  
儿童车





# 2-PCS/一体式



**CR16-Z1-YB36** (CKM24BS-CR16A1)

CRANK LENGTH	曲柄长度	170,172.5,175mm
GEAR	齿数	36T
CRANK MATERIAL	曲柄材质	AL-6061-T6
CRANK FINISH	曲柄涂层	HBK
CHAINRING	齿片	3.4mm STEEL&PA
CHAINRING FINISH	齿片涂层	HBK
OUTSIDE BEARING	外挂轴套	24mm
COMPATIBILITY	变速兼容	11/12/13S
CHAINLINE	链条中心线	49mm
Q-FACTOR	曲柄后下叉距离	179mm
WEIGHT	重量	910g



**CR16-Z2-YA36** (CKR11H-CR16A2)

CRANK LENGTH	曲柄长度	170,172.5,175mm
GEAR	齿数	36/26T
CRANK MATERIAL	曲柄材质	AL-6061-T6
CRANK FINISH	曲柄涂层	HBK
INNER CHAINRING	内圈齿片	2mm Alloy CNC Detail
CHAINRING FINISH	齿片涂层	HBK
OUTER CHAINRING	外圈齿片	5mm Alloy CNC Detail
CHAINRING FINISH	齿片涂层	HBK
OUTSIDE BEARING	外挂轴套	24mm
COMPATIBILITY	变速兼容	11/12S
CHAINLINE	链条中心线	48.5mm
PCD	螺丝分布直径	80mm
Q-FACTOR	曲柄后下叉距离	180mm
WEIGHT	重量	840g



**CR16-Z1-YA34** (CKM24K-CR16A1)

CRANK LENGTH	曲柄长度	170,172.5,175mm
GEAR	齿数	32T,34T
CRANK MATERIAL	曲柄材质	AL-6061-T6
CRANK FINISH	曲柄涂层	HBK
CHAINRING	齿片	3/4mm Alloy CNC Detail
CHAINRING FINISH	齿片涂层	HBK
OUTSIDE BEARING	外挂轴套	24mm
COMPATIBILITY	变速兼容	11/12/13S
CHAINLINE	链条中心线	48mm
Q-FACTOR	曲柄后下叉距离	178mm
WEIGHT	重量	820g



**SR11-A1-YB36** (CKM11BS-SR11A1)

CRANK LENGTH	曲柄长度	170,172.5,175mm
GEAR	齿数	36T
CRANK MATERIAL	曲柄材质	AL-6061-T6
CRANK FINISH	曲柄涂层	HBK
CHAINRING	齿片	3.4mm STEEL&PA
CHAINRING FINISH	齿片涂层	HBK
OUTSIDE BEARING	外挂轴套	24mm
COMPATIBILITY	变速兼容	11S
CHAINLINE	链条中心线	49.5mm
PCD	螺丝分布直径	104mm
Q-FACTOR	曲柄后下叉距离	172mm
WEIGHT	重量	830g

一体式  
公路车  
山地车  
城市车  
折叠车  
儿童车





# 2-PCS/一体式



## SR13-A2-YA36 (CKR11B-SR13A2)

CRANK LENGTH	曲柄长度	170,172.5,175mm
GEAR	齿数	36/26T
CRANK MATERIAL	曲柄材质	AL-6061-T6
CRANK FINISH	曲柄涂层	HBK
INNER CHAINRING	内圈齿片	2mm STEEL
CHAINRING FINISH	齿片涂层	ED
OUTER CHAINRING	外圈齿片	3mm Alloy CNC Detail
CHAINRING FINISH	齿片涂层	HBK
OUTSIDE BEARING	外挂轴套	24mm
COMPATIBILITY	变速兼容	11/12S
CHAINLINE	链条中心线	48mm
PCD	螺丝分布直径	104mm
Q-FACTOR	曲柄后下叉距离	181mm
WEIGHT	重量	850g



## SR13-A2-Y53B (CKR10B-SR13A2)

CRANK LENGTH	曲柄长度	170,172.5,175mm
GEAR	齿数	38/28T
CRANK MATERIAL	曲柄材质	AL-6061-T6
CRANK FINISH	曲柄涂层	HBK
INNER CHAINRING	内圈齿片	2mm STEEL
CHAINRING FINISH	齿片涂层	ED
OUTER CHAINRING	外圈齿片	3mm Alloy CNC Detail
CHAINRING FINISH	齿片涂层	HBK
OUTSIDE BEARING	外挂轴套	24mm
COMPATIBILITY	变速兼容	11/12S
CHAINLINE	链条中心线	48mm
PCD	螺丝分布直径	104mm
Q-FACTOR	曲柄后下叉距离	181mm
WEIGHT	重量	860g



CRANK SET

E-BIKE PART

BELT PULLEY

NEW GB

DERAILLEUR

ED5



SR13  
SR13  
SR13  
SR13  
SR13





2-PCS/一体式



**SAGE11-L2-YA50**  
(VCKR-SAGE11A2)

CRANK LENGTH	曲柄长度	170,172.5,175mm
GEAR	齿数	50/34T
CRANK MATERIAL	曲柄材质	AL-6061-T6
CRANK FINISH	曲柄涂层	HBK
INNER CHAINRING	内圈齿片	3mm Alloy CNC Detail
CHAINRING FINISH	齿片涂层	HBK
OUTER CHAINRING	外圈齿片	5mm Alloy CNC Detail
CHAINRING FINISH	齿片涂层	HBK
OUTSIDE BEARING	外挂轴套	24mm
COMPATIBILITY	变速兼容	11S
CHAINLINE	链条中心线	43.5mm
PCD	螺丝分布直径	110mm
Q-FACTOR	曲柄后下叉距离	155mm
WEGHT	质量	900g



**GA-04-C**  
(SXB5B130L-ED2WR)

CRANK LENGTH	曲柄长度	170,172.5,175mm
GEAR	齿数	53T
CRANK MATERIAL	曲柄材质	AL-6061-T6
CRANK FINISH	曲柄涂层	HBS
INNER CHAINRING	内圈齿片	3mm Alloy CNC Detail
CHAINRING FINISH	齿片涂层	HBK
OUTER CHAINRING	外圈齿片	2mm Alloy CNC Detail
CHAINRING FINISH	齿片涂层	HBK
OUTSIDE BEARING	外挂轴套	24mm
CHAINLINE	链条中心线	45mm
PCD	螺丝分布直径	130mm
Q-FACTOR	曲柄后下叉距离	165mm
WEGHT	质量	1000g



**SAGE11-L2-Y550**  
(DHH110B-SAGE11A2)

CRANK LENGTH	曲柄长度	170,172.5,175mm
GEAR	齿数	50/34T
CRANK MATERIAL	曲柄材质	AL-6061-T6
CRANK FINISH	曲柄涂层	HBK
INNER CHAINRING	内圈齿片	2mm STEEL
CHAINRING FINISH	齿片涂层	ED
OUTER CHAINRING	外圈齿片	2mm STEEL
CHAINRING FINISH	齿片涂层	24mm
OUTSIDE BEARING	外挂轴套	ED
COMPATIBILITY	变速兼容	8/9/10S
CHAINLINE	链条中心线	43.5mm
PCD	螺丝分布直径	110mm
Q-FACTOR	曲柄后下叉距离	155mm
WEGHT	质量	1010g



**CR11-X1-YA34**  
(CKM24D-CR11A1)

CRANK LENGTH	曲柄长度	170,172.5,175mm
GEAR	齿数	30T,32T,34T
CRANK MATERIAL	曲柄材质	AL-6061-T6
CRANK FINISH	曲柄涂层	HBK
CHAINRING	齿片	5mm Alloy CNC Detail offset-3mm
CHAINRING FINISH	齿片涂层	HBK
OUTSIDE BEARING	外挂轴套	24mm
COMPATIBILITY	变速兼容	12S
CHAINLINE	链条中心线	48mm,49.5mm
Q-FACTOR	曲柄后下叉距离	716mm
WEGHT	质量	750g



一体式

一体式





# 2-PCS/一体式



**CR11-21-YA38**  
(CKM24-CR11A1)

CRANK LENGTH	曲柄长度	170,172.5,175mm
GEAR	齿数	32T,34T,36T,38T
CRANK MATERIAL	曲柄材质	AL-6061-T6
CRANK FINISH	曲柄涂层	HBK
CHAINRING	齿片	5mm Alloy CNC Detail
CHAINRING FINISH	齿片涂层	HBK
OUTSIDE BEARING	外挂轴套	24mm
COMPATIBILITY	变速兼容	12S
CHAINLINE	链条中心线	49.5mm,52mm
Q-FACTOR	曲柄后下叉距离	176mm
WEGHT	质量	750g



**SR11-A1-YA38**  
(CKM11-SR11A1)

CRANK LENGTH	曲柄长度	170,172.5,175mm
GEAR	齿数	32T,34T,36T,38T,40T,42T
CRANK MATERIAL	曲柄材质	AL-6061-T6
CRANK FINISH	曲柄涂层	HBK
CHAINRING	齿片	4mm Alloy CNC Detail
CHAINRING FINISH	齿片涂层	HBK
OUTSIDE BEARING	外挂轴套	24mm
COMPATIBILITY	变速兼容	11S
CHAINLINE	链条中心线	49.5mm,52mm
PCD	螺丝分布直径	104mm
Q-FACTOR	曲柄后下叉距离	172mm
WEGHT	质量	800g



**CR12-M1-Y536**  
(CKM24FE-CR12A1)

CRANK LENGTH	曲柄长度	170,172.5,175mm
GEAR	齿数	34T,36T
CRANK MATERIAL	曲柄材质	AL-6061-T6
CRANK FINISH	曲柄涂层	HBK
CHAINRING	齿片	3.4mm STEEL
CHAINRING FINISH	齿片涂层	ED
OUTSIDE BEARING	外挂轴套	24mm
COMPATIBILITY	变速兼容	12S
CHAINLINE	链条中心线	49.5mm,52mm,55mm
Q-FACTOR	曲柄后下叉距离	176mm
WEGHT	质量	900g



**SR11-A1-Y538**  
(CKM11FE-SR11A1)

CRANK LENGTH	曲柄长度	170,172.5,175mm
GEAR	齿数	32T,34T,36T,38T
CRANK MATERIAL	曲柄材质	AL-6061-T6
CRANK FINISH	曲柄涂层	HBK
CHAINRING	齿片	3.4mm STEEL
CHAINRING FINISH	齿片涂层	ED
OUTSIDE BEARING	外挂轴套	24mm
COMPATIBILITY	变速兼容	11S
CHAINLINE	链条中心线	49.5mm,52mm
PCD	螺丝分布直径	104mm
Q-FACTOR	曲柄后下叉距离	172mm
WEGHT	质量	850g



一体式

一体式

一体式

一体式

一体式

一体式

一体式

一体式



2-PCS/一体式



**SR12-B2-YA36**  
(CKR11/CXC2E-SR11A2)

CRANK LENGTH	曲柄长度	170,172.5,175mm
GEAR	齿数	36/22T
CRANK MATERIAL	曲柄材质	AL-6061-T6
CRANK FINISH	曲柄涂层	HBS
INNER CHAINRING	内圈齿片	2mm STEEL
CHAINRING FINISH	齿片涂层	ED
OUTER CHAINRING	外圈齿片	3mm Alloy CNC Detail
CHAINRING FINISH	齿片涂层	HBK
OUTSIDE BEARING	外挂轴套	24mm
COMPATIBILITY	变速兼容	10/11S
CHAINLINE	链条中心线	48.5mm
PCD	螺丝分布直径	104/64mm
Q-FACTOR	曲柄后下叉距离	155mm
WEGHT	质量	900g



**SR13-A1-YA32**  
(CKM11B-SR13A1)

CRANK LENGTH	曲柄长度	170,172.5,175mm
GEAR	齿数	32T,34T,36T,38T
CRANK MATERIAL	曲柄材质	AL-6061-T6
CRANK FINISH	曲柄涂层	HBK
CHAINRING	齿片	4mm Alloy CNC Detail
CHAINRING FINISH	齿片涂层	HBK
OUTSIDE BEARING	外挂轴套	24mm
COMPATIBILITY	变速兼容	11S
CHAINLINE	链条中心线	49.5mm,52mm
PCD	螺丝分布直径	104mm
Q-FACTOR	曲柄后下叉距离	176mm
WEGHT	质量	810g

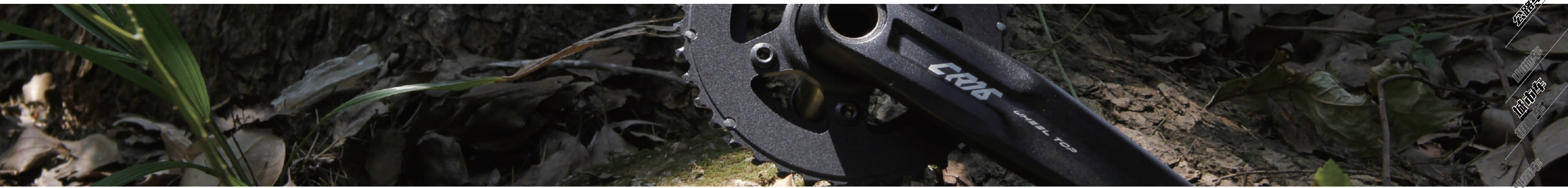

**SR12-B2-YA38**  
(CKR10/CXC2E-SR12A2)

CRANK LENGTH	曲柄长度	170,172.5,175mm
GEAR	齿数	38/24T
CRANK MATERIAL	曲柄材质	AL-6061-T6
CRANK FINISH	曲柄涂层	HBS
INNER CHAINRING	内圈齿片	2mm STEEL
CHAINRING FINISH	齿片涂层	ED
OUTER CHAINRING	外圈齿片	3mm Alloy CNC Detail
CHAINRING FINISH	齿片涂层	HBK
OUTSIDE BEARING	外挂轴套	24mm
COMPATIBILITY	变速兼容	10/11S
CHAINLINE	链条中心线	48.5mm
PCD	螺丝分布直径	104/64mm
Q-FACTOR	曲柄后下叉距离	176mm
WEGHT	质量	880g



**SR13-A1-YA38**  
(CKM11-SR13A1)

CRANK LENGTH	曲柄长度	170,172.5,175mm
GEAR	齿数	32T,34T,36T,38T,40T,42T
CRANK MATERIAL	曲柄材质	AL-6061-T6
CRANK FINISH	曲柄涂层	HBK
CHAINRING	齿片	4mm Alloy CNC Detail
CHAINRING FINISH	齿片涂层	HBK
OUTSIDE BEARING	外挂轴套	24mm
COMPATIBILITY	变速兼容	11/12S
CHAINLINE	链条中心线	49.5mm,52MM
PCD	螺丝分布直径	104mm
Q-FACTOR	曲柄后下叉距离	176mm
WEGHT	质量	850g



SR12 SR13



2-PCS/一体式



**SR13-G1-YA34**  
(CKM13-SR13A1)

CRANK LENGTH	曲柄长度	170,172.5,175mm
GEAR	齿数	30T,32T,34T
CRANK MATERIAL	曲柄材质	AL-6061-T6
CRANK FINISH	曲柄涂层	HBK
CHAINRING	齿片	4mm Alloy CNC Detail
CHAINRING FINISH	齿片涂层	HBK
OUTSIDE BEARING	外挂轴套	24mm
COMPATIBILITY	变速兼容	11S
CHAINLINE	链条中心线	49.5mm,52MM
PCD	螺丝分布直径	96mm
Q-FACTOR	曲柄后下叉距离	176mm
WEGHT	质量	810g



**SR13-B2-YA36**  
(CKR11-SR13A2)

CRANK LENGTH	曲柄长度	170,172.5,175mm
GEAR	齿数	36/22T
CRANK MATERIAL	曲柄材质	AL-6061-T6
CRANK FINISH	曲柄涂层	HBK
INNER CHAINRING	内圈齿片	2mm STEEL
CHAINRING FINISH	齿片涂层	ED
OUTER CHAINRING	外圈齿片	3mm Alloy CNC Detail
CHAINRING FINISH	齿片涂层	HBK
OUTSIDE BEARING	外挂轴套	24mm
COMPATIBILITY	变速兼容	10/11S
CHAINLINE	链条中心线	48.5mm
PCD	螺丝分布直径	104/64mm
Q-FACTOR	曲柄后下叉距离	176mm
WEGHT	质量	890g



**SR13-A1-YB32**  
(CKM11BS-SR13A1)

CRANK LENGTH	曲柄长度	170,172.5,175mm
GEAR	齿数	32T,34T,36T,38T
CRANK MATERIAL	曲柄材质	AL-6061-T6
CRANK FINISH	曲柄涂层	HBK
CHAINRING	齿片	3.4mm STEEL&PA
CHAINRING FINISH	齿片涂层	HBK
OUTSIDE BEARING	外挂轴套	24mm
COMPATIBILITY	变速兼容	10/11S
CHAINLINE	链条中心线	49.5mm
CHAINLINE	链条中心线	52mm BOOST version
PCD	螺丝分布直径	104mm
Q-FACTOR	曲柄后下叉距离	172mm
WEGHT	质量	900g



**SR13-B2-YA38**  
(CKR10-SR13A2)

CRANK LENGTH	曲柄长度	170,172.5,175mm
GEAR	齿数	38/24T
CRANK MATERIAL	曲柄材质	AL-6061-T6
CRANK FINISH	曲柄涂层	HBK
INNER CHAINRING	内圈齿片	2mm STEEL
CHAINRING FINISH	齿片涂层	ED
OUTER CHAINRING	外圈齿片	3mm Alloy CNC Detail
CHAINRING FINISH	齿片涂层	HBK
OUTSIDE BEARING	外挂轴套	24mm
COMPATIBILITY	变速兼容	10/11S
CHAINLINE	链条中心线	48.5mm
PCD	螺丝分布直径	104/64mm
Q-FACTOR	曲柄后下叉距离	176mm
WEGHT	质量	920g



SR13  
POWERED BY WHEEL TOP





2-PCS/一体式



**SR13-G2-Y540**  
(DCXC2E/E3-SR13A2)

CRANK LENGTH	曲柄长度	170,172.5,175mm
GEAR	齿数	40/28T
CRANK MATERIAL	曲柄材质	AL-6061-T6
CRANK FINISH	曲柄涂层	HBK
INNER CHAINRING	内圈齿片	2mm STEEL
CHAINRING FINISH	齿片涂层	ED
OUTER CHAINRING	外圈齿片	3mm STEEL
CHAINRING FINISH	齿片涂层	ED
OUTSIDE BEARING	外挂轴套	24mm
COMPATIBILITY	变速兼容	10S
CHAINLINE	链条中心线	49.5mm
PCD	螺丝分布直径	96mm
Q-FACTOR	曲柄后下叉距离	176mm
WEGHT	质量	990g



**SR13-G3-YA40**  
(TCXC2L-SR13A3)

CRANK LENGTH	曲柄长度	170,172.5,175mm
GEAR	齿数	40/30/22T
CRANK MATERIAL	曲柄材质	AL-6061-T6
CRANK FINISH	曲柄涂层	HBK
INNER CHAINRING	内圈齿片	2mm STEEL
CHAINRING FINISH	齿片涂层	ED
OUTER CHAINRING	外圈齿片	3mm Alloy CNC Detail
CHAINRING FINISH	齿片涂层	HBK
OUTSIDE BEARING	外挂轴套	24mm
COMPATIBILITY	变速兼容	10S
CHAINLINE	链条中心线	50mm
PCD	螺丝分布直径	96/64mm
Q-FACTOR	曲柄后下叉距离	176mm
WEGHT	质量	950g



**SR13-A3-YA42**  
(TCXC2L-SR13A3)

CRANK LENGTH	曲柄长度	170,172.5,175mm
GEAR	齿数	42/32/24T
CRANK MATERIAL	曲柄材质	AL-6061-T6
CRANK FINISH	曲柄涂层	HBK
INNER CHAINRING	内圈齿片	2mm STEEL
CHAINRING FINISH	齿片涂层	ED
OUTER CHAINRING	外圈齿片	3mm Alloy CNC Detail
CHAINRING FINISH	齿片涂层	HBK
OUTSIDE BEARING	外挂轴套	24mm
COMPATIBILITY	变速兼容	10S
CHAINLINE	链条中心线	50mm
Q-FACTOR	曲柄后下叉距离	176mm
PCB	螺丝分布直径	104/96mm
WEGHT	质量	950g



**SR13-A3-Y544**  
(TCXC2D-SR13A3)

CRANK LENGTH	曲柄长度	170,172.5,175mm
GEAR	齿数	44/32/22T
CRANK MATERIAL	曲柄材质	AL-6061-T6
CRANK FINISH	曲柄涂层	HBK
INNER CHAINRING	内圈齿片	2mm STEEL
CHAINRING FINISH	齿片涂层	ED
OUTER CHAINRING	外圈齿片	2mm STEEL
CHAINRING FINISH	齿片涂层	ED
OUTSIDE BEARING	外挂轴套	24mm
COMPATIBILITY	变速兼容	9S
CHAINLINE	链条中心线	50mm
Q-FACTOR	曲柄后下叉距离	176mm
PCD	螺丝分布直径	104mm
WEGHT	质量	1090g



SR13  
POWERED BY HANSON TOP





# 2-PCS/一体式



SR13-63-Y540 (TCXC2E-SR13A3)		
CRANK LENGTH	曲柄长度	170,172.5,175mm
GEAR	齿数	40/30/22T
CRANK MATERIAL	曲柄材质	AL-6061-T6
CRANK FINISH	曲柄涂层	HBK
INNER CHAINRING	内圈齿片	2mm STEEL
CHAINRING FINISH	齿片涂层	ED
OUTER CHAINRING	外圈齿片	2mm STEEL
CHAINRING FINISH	齿片涂层	ED
OUTSIDE BEARING	外挂轴套	24mm
COMPATIBILITY	变速兼容	10S
CHAINLINE	链条中心线	50mm
PCD	螺丝分布直径	96/64mm
Q-FACTOR	曲柄后下叉距离	176mm
WEGHT	质量	1030g



SR13-83-Y542 (TCXC2C-SR13A3)		
CRANK LENGTH	曲柄长度	170,172.5,175mm
GEAR	齿数	40/30/22T
CRANK MATERIAL	曲柄材质	AL-6061-T6
CRANK FINISH	曲柄涂层	HBK
INNER CHAINRING	内圈齿片	2mm STEEL
CHAINRING FINISH	齿片涂层	ED
OUTER CHAINRING	外圈齿片	2mm STEEL
CHAINRING FINISH	齿片涂层	ED
OUTSIDE BEARING	外挂轴套	24mm
COMPATIBILITY	变速兼容	9S
CHAINLINE	链条中心线	50mm
PCD	螺丝分布直径	96mm
Q-FACTOR	曲柄后下叉距离	176mm
WEGHT	质量	1030g



## INTEGRATED BOTTOM BRACKETS

BB2497 (Thread type BOTTOM BRACKETS)  
(螺纹式中轴套)

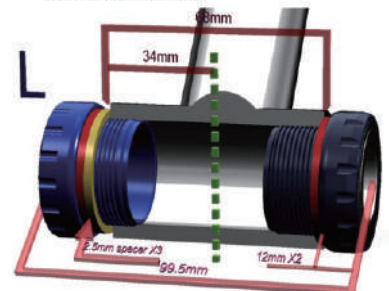

R  
BB SHELL WIDTH: 86.5,92MM  
BB 宽度  
BB compatibility: Diameter of assembly hole of frame 41mm  
WITH  $\phi$ 24mm SPINDLE  
BB CUP: ALLOY,FORGED AND CNC MACH.EXTERNAL  
碗组 METAL GREY ANO.CUPS  
CENTER SLEEVE: P;ASTIC,GREY  
中轴管



BB2495 (Thread type BOTTOM BRACKETS)  
(螺纹式中轴套)

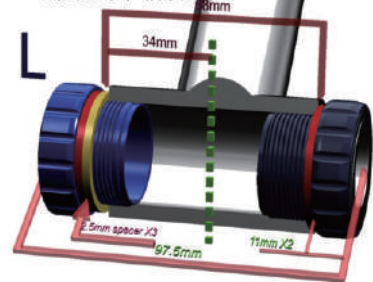

R  
BB SHELL WIDTH: 86.5,92MM  
BB 宽度  
BB compatibility: Diameter of assembly hole of frame 41mm  
WITH  $\phi$ 24mm SPINDLE  
BB CUP: ALLOY,FORGED AND CNC MACH.EXTERNAL  
碗组 METAL GREY ANO.CUPS  
CENTER SLEEVE: P;ASTIC,GREY  
中轴管



PFBB2492 (PRESS FIT ALLOY BOTTOM BRACKETS)  
(压入式中轴套)

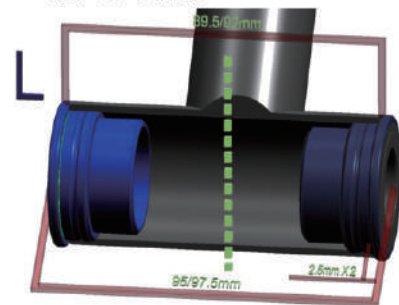

R  
BB SHELL WIDTH: 86.5,92MM  
BB 宽度  
BB compatibility: Diameter of assembly hole of frame 41mm  
WITH  $\phi$ 24mm SPINDLE  
BB CUP: ALLOY.  
碗组  
CENTER SLEEVE: P;ASTIC,GREY  
中轴管



一体式  
公路车  
山地车  
城市车  
折叠车  
儿童车



**ROAD**

**公路车**







# ROAD



## DHH110C-QS01

(DHH110C-QS01(G4HH) 50/34)

MODEL	DHH110C-QS01
	DHH110C-QS01(G4HH) 50/34
MATERIAL	FORGED ALLOY-6061-T6
LENGTH	170
GEAR	50/34
INNER	STEEL
OUTER	STEEL
PCD	110
COMPATIBILITY	8 9S
CHAIN LINE	44MM



## HIGHKU-7SB

( DSS130C-RD2WR )



## HIGHKU-7WB

( DSS130B-RD2WR )



## HIGHKU-7SBB

( DSS130D-HD2WR )



## HIGHKU-7WB-CD

( DSS110A-CD2WR )



## ARROW-430

( DSS130L-ED2WR )



## ARROW-420

( DSS130L-ED2WR )

MODEL		HIGHKU-7WB (DSS130B-RD2WR)	HIGHKU-7SB (DSS130C-RD2WR)	HIGHKU-7SBB (DSS130D-HD2WR)
CRANK	MATERIAL	Forged Alloy-6061-T6	Forged Alloy-6061-T6	Forged Alloy-6061-T6
	LENGTH	170,175mm	170,175mm	170,175mm
CHAINRINGS	GEAR	53/39T	53/39T	53/39T
	INNER	3.0mm Alloy 100% CNC	3.0mm Alloy 100% CNC	Steel
	OUTER	4.0mm Alloy 100% CNC	4.0mm Alloy 100% CNC	3.0mm Alloy 100% CNC
PCD		130mm	130mm	130mm
COMPATIBILITY		9S	9S	10S
CHAIN LINE		44mm	45mm	44.3mm
B.B.AXLE		110.5mm	110.5mm	110.5mm

MODEL		HIGHKU-7WB-CD (DSS110A-CD2WR)	ARROW-430 (DSS130L-RD2WR)	ARROW-420 (DSS130L-HD2WR)
CRANK	MATERIAL	Forged Alloy-6061-T6	Forged Alloy-6061-T6	Forged Alloy-6061-T6
	LENGTH	170,172.5,175mm	170,172.5,175mm	170,172.5,175mm
CHAINRINGS	GEAR	50/34T	53/39T	53/39T
	INNER	3.0mm Alloy 100% CNC	3.0mm Alloy 100% CNC	Steel
	OUTER	4.0mm Alloy 100% CNC	3.0mm Alloy 100% CNC	3.0mm Alloy 100% CNC
PCD		110mm	130mm	130mm
COMPATIBILITY		9S	9S	9S
CHAIN LINE		46mm	44.3mm	44.3mm
B.B.AXLE		110.5mm	110.5mm	110.5mm



CRANK SET

E-BIKE PART

BELT PULLEY

NEW GB

DERAILLEUR

EDS

公路车

山地车

城市车

折叠车

儿童车





# ROAD



CRANK SET

E-BIKE PART

BELT PULLEY

NEW GB

DERAILLEUR

ED5



**ARROW-110**  
( DSS110-CD2WR )



**ARROW-320\*(G)**  
( DHH130-ED2WR(G5QT) )



**DHH110B-CE**  
( DHH110B-CE2WR(G5QH) )



**DSS110-CE2WR**



**ARROW-320**  
( DHH130-ED2WR )



**ARROW-330**  
( THH130-ED2R )



**SR-11-D**  
( SR-11-D(CKM11FE-SR11) )



**SR-11-E**  
( CKM11FE-SRG(28GA) )

MODEL		ARROW-110 (DSS110-CD2WR)	ARROW-320(G) (DHH130-ED2WR(G5QT))	ARROW-320 (DHH130-ED2WR)	ARROW-330 (THH130-ED2R)
CRANK	MATERIAL	Forged Alloy-6061-T6	Forged Alloy-6061-T6	Forged Alloy-6061-T6	Forged Alloy-6061-T6
	LENGTH	165,170,175mm	170,175mm	170,175mm	170,175mm
CHAINRINGS	GEAR	50/34T	52/42T	52/42T	52/42/30T
	INNER	Steel	Steel	Steel	Steel
	CENTER	/	/	/	Steel
	OUTER	Steel	Steel	Steel	Steel
PCD		110mm	130mm	130mm	130/74mm
CHAINGUARD COVER		/	Plastic	/	/
COMPATIBILITY		8/9S	8S	8S	8S
CHAIN LINE		46mm	44mm	44mm	45mm
B.B.AXLE		110.5mm	110.5mm	172.5mm	116mm

MODEL		DHH110B-CE (DHH110B-CE2WR(G5QH))	DSS110-CE2WR	SR-11-D (SR-11-C(CKM11FE-SR11))	SR-11-E (CKM11FE-SRG(28GA))
CRANK	MATERIAL	Forged Alloy-6061-T6	Forged Alloy-6061-T6	Forged Alloy-6061-T6	Forged Alloy-6061-T6
	LENGTH	170,175mm	170,175mm	170,172.5,175mm	170,175mm
CHAINRINGS	GEAR	50/34T	50/34T	32T,34T,36T,38T防脱链齿形	32T,34T,36T,38T防脱链齿形
	INNER	Steel	Steel	/	/
	OUTER	Steel	Steel	Steel	Steel
PCD		110mm	110mm	104mm	104mm
CHAINGUARD COVER		Plastic	/	/	Alloy
COMPATIBILITY		8S	8/9S	/	/
CHAIN LINE		45mm	45.5mm	49.5mm	49.5mm
B.B.AXLE		110.5mm	110mm	120mm	120mm

公路车

公路车

公路车

公路车

公路车

公路车

公路车

公路车

公路车

公路车

公路车

公路车

公路车





CRANK SET

E-BIKE PART

BELT PULLEY

NEW GB

DERAILLEUR

ED5

**MTB 山地车**

## SKMT1-QB01

MODEL	SKMT1-QB01
	SKMT1-QB01(G3PX)-32/40/42
MATERIAL	FORGED ALLOY-6061-T6
LENGTH	165 170
GEAR	32T 40T 42T
MATERIAL	3.0MM NW STEEL
PCD	/
CHAINGUARD	PLASTIC
CHAIN LINE	49MM



## SKMT1-SMA

MODEL	SKMT1-SMA
	SKMT1-SMA-32/40/42
MATERIAL	FORGED ALLOY-6061-T6
LENGTH	140 152 165 170 175
GEAR	32T 40T 42T
MATERIAL	3.0MM NW STEEL
PCD	/
CHAINGUARD	/
CHAIN LINE	49MM
BB	124.5MM



## SPBXB-SMA

MODEL	SPBXB-SMA
	SPBXB-SMA(G3PX)-28/32/40
MATERIAL	FORGED ALLOY-6061-T6
LENGTH	140 152 165 170 175
GEAR	32T 40T 42T
MATERIAL	2.0 STEEL
PCD	/
CHAINGUARD	PLASTIC
CHAIN LINE	49MM



公路车

公路车

山地车

旅行车

折叠车

儿童车





### TAIKLONG-AB450A

TCXP2R-RX1



### TAIKLONG-HT450S

TCXC2D-HT1(G4RE)

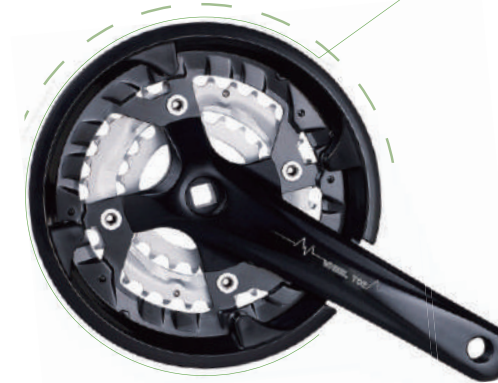

### TCXC2L-HF1

TCXC2L-HF1(G4SE)



### TCXC2E-HF1

TCXC2E-HF1(G4SE)



### TCXC2L-HT1

TCXC2L-HT1(G4SE)



### TCXC2E-HU1

TCXC2E-HU1(G4SE)

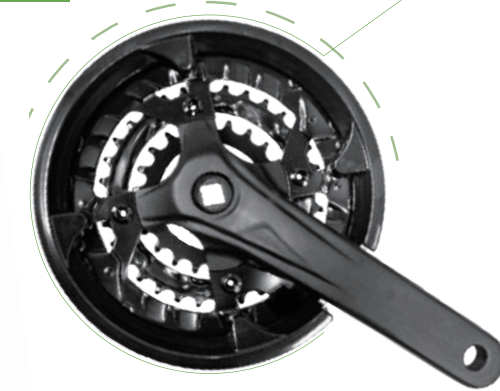

MODEL		TAIKLONG-AB450A (TCXP2R-RX1)	TCXC2L-HF1 (TCXC2L-HF1(G4SE))	TCXC2E-HF1 (TCXC2E-HF1(G4SE))
CRANK	MATERIAL	Forged Alloy-6061-T6	Forged Alloy-6061-T6	Forged Alloy-6061-T6
	LENGTH	170,175mm	170,175mm	170,175mm
CHAINRINGS	GEAR	48/38/28T	40/30/22T	40/30/22T
	INNER	Steel	Steel	Steel
	CENTER	Steel	Steel	Steel
	OUTER	3.0mm Alloy 100% CNC	3.0mm Alloy	Steel
PCD		104/64mm	96/64mm	96/64mm
CHAINGUAED COVER		/	Plastic	Plastic
COMPATIBILITY		8S	9/10S	9/10S
CHAIN LINE		48.5mm	48.5mm	48.5mm
B.B.AXLE		117.5mm	113mm	113mm

MODEL		TAIKLONG-HT450S (TCXC2D-HT1(G4RE))	TCXC2L-HT1 (YCX2L-HT1(G4SE))	TCXC2E-HU1 (YCX2E-HU1(G4SE))
CRANK	MATERIAL	Forged Alloy-6061-T6	Forged Alloy-6061-T6	Forged Alloy-6061-T6
	LENGTH	170,175mm	170,175mm	170,175mm
CHAINRINGS	GEAR	44/32/22T	42/32/24T	42/32/24T
	INNER	Steel	Steel	Steel
	CENTER	Steel	Steel	Steel
	OUTER	Steel	3.0mm Alloy	Steel
PCD		104/64mm	104/64mm	104/64mm
CHAINGUAED COVER		Plastic	Plastic	Plastic
COMPATIBILITY		9S	10S	10S
CHAIN LINE		48.5mm	50mm	50mm
B.B.AXLE		113mm	116mm	116mm

公路车

公路车

山地车

山地车

山地车

儿童车





### DCXC2E-HF2

DCXC2E-HF2



### HAWK-HG1

TCXC2RC-HG1



### DCXC2D-HX1

### HAWK-HX1

TCXC2C-HX1



### HAWK-DX(A)

TCXC2C-DX1



### TCRF4-VA

TCRF4-VA(H4RE)(A4F4)

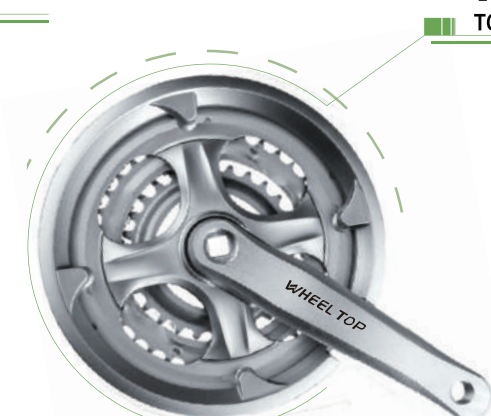

MODEL		DCXC2E-HF2 (DCXC2E-HF2)	DCXC2D-HX1 (YCX2E-HT1(G4SE))	HAWK-HX1 (TCXC2C-HX1)
CRANK	MATERIAL	Forged Alloy-6061-T6	Forged Alloy-6061-T6	Forged Alloy-6061-T6
	LENGTH	170,175mm	165,170,175mm	170,175mm
CHAINRINGS	GEAR	40/28T	48/36T	48/38/28T 42/32/22T 42/34/24T
	INNER	Steel	Steel	Steel
	CENTER	/	/	Steel
	OUTER	Steel	Steel	Steel
PCD		96/64mm	104mm	104/64mm
CHAINGUAED COVER		/	7	/
COMPATIBILITY		10S	8S	10S
CHAIN LINE		50mm	48.5mm	47.5mm
B.B.AXLE		118mm	113mm	118mm

MODEL		HAWK-HG1 (TCXC2RC-HG1)	HAWK-DX(A) (TCXC2C-DX1)	TCXC2L-HT1 (TCRF-VA(G4R4)(A4F4))
CRANK	MATERIAL	Forged Alloy-6061-T6	Forged Alloy-6061-T6	Forged Alloy-6061-T6
	LENGTH	170,175mm	170,175mm	170,175mm
CHAINRINGS	GEAR	44/32/22T	48/38/28T	48/38/28T
	INNER	Steel	Steel	Steel
	CENTER	Steel	Steel	Steel
	OUTER	Steel	Steel	Steel
PCD		104/64mm	104/64mm	104/64mm
CHAINGUAED COVER		/	/	Plastic
COMPATIBILITY		9S	8/7S	7/8S
CHAIN LINE		48.5mm	47.5mm	48mm
B.B.AXLE		113mm	110.5mm	120mm

公路车

公路车

山地车

山地车

山地车

儿童车





**DCRX1-SMA**  
DCRX1-SMA(G4XD)



**DCRX1-SMA**  
DCRX1-SMA(G4FE)(LFE46)



**TCRF4-SMA**  
TCRF4-SMA(G4RB)(A4G4)



**TCRF4-SMA**  
TCRF4-SMA(G4RB)(LFG)



**DCRX1-SMA**  
DCRX1-SMA(G4FE)(LFE36)



**TCRF4-SMA**  
TCRF4-SMA(G4XD)



**TCSH4-SMA**  
TCSH4-SMA(G4SH)(LSH)



**TCRF4-SMF**  
TCRF4-SMF(G4RB)(LFG)



MODEL		DCRX1-SMA (DCRX1-SMA(G4XD))	DCRX1-SMA (DCRX1-SMA(G4FE)(LFE46))	DCRX1-SMA (DCRX1-SMA(G4FE)(LFE36))	TCRF4-SMA (TCRF4-SMA(G4XD))
CRANK	MATERIAL	Forged Alloy-6061-T6	Forged Alloy-6061-T6	Forged Alloy-6061-T6	Forged Alloy-6061-T6
	LENGTH	152,165,170,175mm	152,165,170,175mm	152,165,170,175mm	152,165,170,175mm
CHAINRINGS	GEAR	46/30T	46/30T	36/22T	48/38/28T
	INNER	Steel	Steel	Steel	Steel
	CENTER	/	/	/	Steel
	OUTER	Steel	Steel	Steel	Steel
PCD		104/64mm	96/64mm	104mm	104/64mm
CHAINGUARD COVER		Plastic	Plastic	Plastic	Plastic
COMPATIBILITY		8S	8S	8S	8/7S
CHAIN LINE		49mm	49mm	49mm	48mm
B.B.AXLE		124.5mm	124.5mm	124.5mm	120mm

MODEL		TCRF4-SMA (TCRF4-SMA(G4RB)(A4G4))	TCRF4-SMA (TCRF4-SMA(G4RB)(LFG))	TCSH4-SMA (TCSH4-SMA(G4SH)(LSH))	TCRF4-SMF (TCRF4-SMF(G4RB)(LFG))
CRANK	MATERIAL	Forged Alloy-6061-T6	Forged Alloy-6061-T6	Forged Alloy-6061-T6	Forged Alloy-6061-T6
	LENGTH	152,165,170,175mm	152,165,170,175mm	165,170,175mm	170mm
CHAINRINGS	GEAR	48/38/28T	48/38/28T	42/34/24T	48/38/28T
	INNER	Steel	Steel	Steel	Steel
	CENTER	Steel	Steel	Steel	Steel
	OUTER	Steel	Steel	Steel	Steel
CHAINGUARD COVER		Plastic	Plastic	Plastic	Plastic
COMPATIBILITY		8/7S	8/7S	7/8S	7/8S
CHAIN LINE		48mm	48mm	48.7mm	48mm
B.B.AXLE		120mm	120mm	124.5mm	120mm

公路车  
山地车  
儿童车





MTB



CRANK SET

E-BIKE PART

BELT PULLEY

NEW GB

DERAILLEUR

ED5

**TCRF4-MGC**  
(TCRF4-MGC(G4RD))



**TCSH-SMA**  
(TCSH4-SMA(G4SH)(LSU))



**TCSH4-SMF**  
(TCSH4-SMF(G4SH)(LSH))



**TCSH4-SMA**  
(TCSH4-SMA(G4XW))



**TCXH-SMA(RE)**  
(TCXH-SMA(G4RE)(A4AH))



**TCXH-SMA(AF)**  
(TCXH-SMA(G4AF)(A4AH))



MODEL		TCRF4-MGC (TCRF4-MGC(G4RD))	TCSH-SMF (TCSH4-SMF(G4SH)(LSH))	TCSH4-SMA (TCSH4-SMA(G4XW))
CRANK	MATERIAL	Forged Alloy-6061-T6	Forged Alloy-6061-T6	Forged Alloy-6061-T6
	LENGTH	165,170mm	170mm	165,170,175mm
CHAINRINGS	GEAR	48/38/28T	42/34/24T	42/34/24T
	INNER	Steel	Steel	Steel
	CENTER	Steel	Steel	Steel
	OUTER	Steel	Steel	Steel
PCD		/	/	/
CHAINGUAED COVER		Plastic	Plastic	Plastic
COMPATIBILITY		7/8S	7/8S	7/8S
CHAIN LINE		48mm	48.7mm	48.7mm
B.B.AXLE		120mm	124.5mm	124.5mm

MODEL		TCSH-SMA (TCSH4-SMA(G4SH)(LSU))	TCSH-SMA(RE) (TCXH-SMA(G4RE)(A4AH))	TCXH-SMA(AF) (TCXH-SMA(G4AF)(A4AH))
CRANK	MATERIAL	Forged Alloy-6061-T6	Forged Alloy-6061-T6	Forged Alloy-6061-T6
	LENGTH	165,170,175mm	165,170,175mm	165,170,175mm
CHAINRINGS	GEAR	42/34/24T	44/32/22T	42/32/22T
	INNER	Steel	Steel	Steel
	CENTER	Steel	Steel	Steel
	OUTER	Steel	Steel	Steel
PCD		/	/	/
CHAINGUAED COVER		Plastic	Plastic	Plastic
COMPATIBILITY		7/8S	9S	7/8S
CHAIN LINE		48.7mm	48.7mm	48.7mm
B.B.AXLE		124.5mm	124.5mm	124.5mm

公路车  
山地车  
城市车  
儿童车





**TCSH4-HE3**  
TCSH4-HE3(G4SH)(LSU)



**TCSH4-SH**  
TCSH-SH(G4SH)(LSH)



**TCSH4-CFPF**  
TCSH4-CFPF(G4SH)



**TCSH4-CFRY**  
TCSH4-CFRY(G4RY)



**TCSH4-SMA**  
TCSH4-SMA(G4AF)(A4AF)



**TCSH4-CFPG**  
TCSH4-CFPG(G4SH)



**TCSH4-CFPG**  
TCRF4-CFPG(G4RB)



**TCSH4-MZ(B)**  
TCSH4-MZ(G4SH)(CSH)



MODEL		TCSH4-HE3 (TCSH4-HE3(G4SH)(LSU))	TCSH4-SH (TCSH4-SH(G4SH)(LSH))	TCSH4-SMA (TCSH-SMA(G4AF)(A4AF))	TCSH4-CFPG (TCSH4-CFPG(G4SH))
CRANK	MATERIAL	Forged Alloy-6061-T6	Forged Alloy-6061-T6	Forged Alloy-6061-T6	Forged Alloy-6061-T6
	LENGTH	170,175mm	127/152mm	165,170,175mm	152,170,175mm
CHAINRINGS	GEAR	42/34/24T	42/34/24T	42/34/24T	42/34/24T
	INNER	Steel	Steel	Steel	Steel
	CENTER	Steel	Steel	Steel	Steel
	OUTER	Steel	Steel	Steel	Steel
CHAINGUAED COVER		Plastic	Plastic	Plastic	Plastic
COMPATIBILITY		7/8S	7/8S	7/8S	7/8S
CHAIN LINE		48.7mm	48.7mm	48.7mm	48mm
B.B.AXLE		124.5mm	124.5mm	124.5mm	118mm

MODEL		TCSH4-CFPF (TCSH4-CFPF(G4SH))	TCSH4-CFRY (TCSH4-CFRY(G4RY))	TCSH4-CFPG (TCSH4-CFPG(G4RB))	TCSH4-MZ(B) (TCSH4-MZ(G4SH)(CSH))
CRANK	MATERIAL	Forged Alloy-6061-T6	Forged Alloy-6061-T6	Forged Alloy-6061-T6	Forged Alloy-6061-T6
	LENGTH	170mm	170mm	165,170,175mm	152,170mm
CHAINRINGS	GEAR	42/34/24T	42/34/24T	48/38/28T	42/34/24T
	INNER	Steel	Steel	Steel	Steel
	CENTER	Steel	Steel	Steel	Steel
	OUTER	Steel	Steel	Steel	Steel
CHAINGUAED COVER		Plastic	Plastic	Plastic	Plastic
COMPATIBILITY		7/8S	7/8S	8/7S	7/8S
CHAIN LINE		48mm	48.5mm	48.3mm	48.7mm
B.B.AXLE		118mm	116mm	116mm	124.5mm

公路车

公路车

山地车

山地车

山地车

山地车

山地车

山地车

山地车

山地车

山地车

山地车

山地车





**CITY &  
FOLDING**

**城市车  
/ 折叠车**



**LANXI-52AA**

( SXB5B130A-ED2WR(25GA-2) )

**SOB5B130Y-BY2WR**

( SXB5B130Y-BY2WR(29GA-48) )

**SOB5B130Y-BY2WR****LANXI-45AA**

( SXB5B130A-ED2WR(45GA-2) )

**LANXI-42AA**

( SXB5B130A-ED2WR(23GA-2) )

**SPB5B110S-CE2WR**

( SPB5B110S-CE2WR(110GA) )

**SOB5B110S-CE2WR**

MODEL		LANXI-52AA (SXB5B130A-ED2WR(25GA-2))	LANXI-45AA (SXB5B130A-ED2WR(45GA-2))	LANXI-42AA (SXB5B130A-ED2WR(23GA-2))
CRANK	MATERIAL	Forged Alloy-6061-T6	Forged Alloy-6061-T6	Forged Alloy-6061-T6
	LENGTH	165,170,175mm	165,170,175mm	165,170mm
CHAINRINGS	GEAR	3/32" 52T	3/32" 45T	3/32" 42T
	MATERIAL	3.0mm Alloy	3.0mm Alloy	3.0mm Alloy
PCD		130mm	130mm	130mm
CHAINGUAED COVER		Double Alloy	Double Alloy	Double Alloy
CHAIN LINE		45mm	45mm	45mm
B.B.AXLE		118mm	118mm	118mm

MODEL		SOB5B130Y-BY2WR (SOB5B130Y-BY2WR(29GA-48))	SOB5B130Y-BY2WR	SPB5B110S-CE2WR (SPB5B110S-CE2WR(110GA))	SOB5B110S-CE2WR
CRANK	MATERIAL	Forged Alloy-6061-T6	Forged Alloy-6061-T6	Forged Alloy-6061-T6	Forged Alloy-6061-T6
	LENGTH	165,170mm	165,170mm	170,175mm	170,175mm
CHAINRINGS	GEAR	1/8" 44T 48T	1/8" 46T 52T	3/32" 50T	46T
	MATERIAL	3.0mm Alloy	3.0mm Alloy 100%CNC	Steel	Steel
PCD		130mm	130mm	110mm	110mm
CHAIN LINE		45mm	45mm	45mm	45mm
B.B.AXLE		127.5mm	117.5mm	117.5mm	121.5mm

公路车

山地车

城市车

折叠车

儿童车



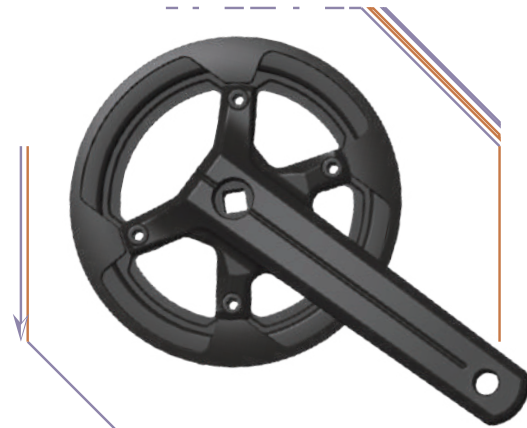

**SCKG12-SAGE13A1-D**  
( SCKG12-SAGE13A1-D(G4KG) )



**SXB5B130S-RD2W**  
( SXB5B130S-RD2W(G5TEO/I) )



**RAMBLF-EX44A**  
( SCXAC-EX2R(GCAC) )

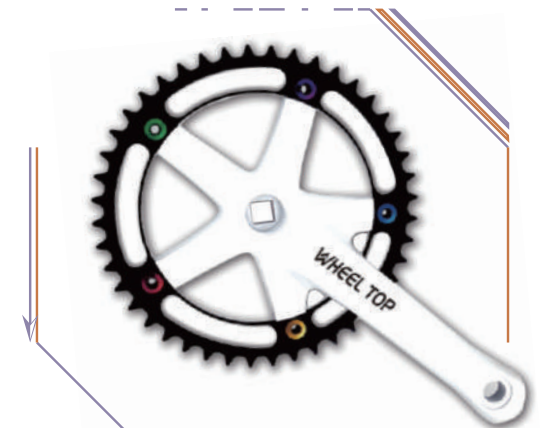

**SOB5B144C-MAX1**



**SXB5A-MAX1**



**SXB5B130W-RD2W**

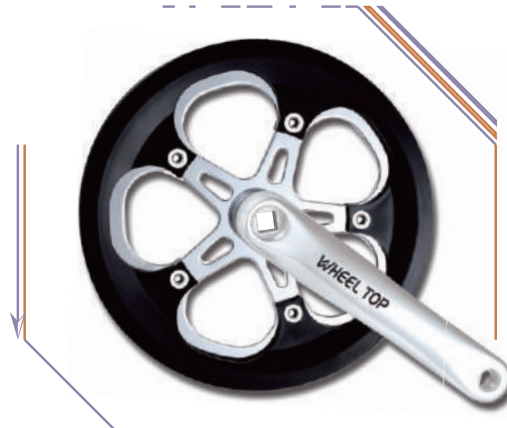

**SXB5B-MGC**  
( SXB5B-MGC(G5QBI-2) )



**SPB5B-MT**  
( SPB5B-MT(G5TDO/G5TBO) )

MODEL		SCKG12-SAGE13A1-D (SCKG12-SAGE13A1-D(G4KG))	SXB5B130S-RD2W (SXB5B130S-RD2W(G5TEO/I))	SXB5A-MAX1	SXB5B130W-RD2W
CRANK	MATERIAL	Forged Alloy-6061-T6	Forged Alloy-6061-T6	Forged Alloy-6061-T6	Forged Alloy-6061-T6
	LENGTH	170, 175mm	170,175mm	165,170mm	165,170mm
CHAINRINGS	GEAR	3/32" 40T	3/32" 45T	3/32" 46T 48T	3/32" 42T 44T 46T 48T
	MATERIAL	2014	Steel	3.0mm Alloy 110% CNC	3.0mm Alloy 100% CNC
PCD		110mm	130mm	144mm	130mm
CHAINGUAED COVER		Plastic	Double Plastic	/	/
CHAIN LINE		45mm	45mm	46.5mm	46.5mm
B.B.AXLE		110mm	108mm	108mm	108mm

MODEL		RAMBLF-EX44A (SCXAC-EX2R(GCAC))	SOB5B144C-MAX1	SXB5B-MGC (SXB5B-MGC(G5QBI-2))	SPB5B-MT (SPB5B-MT(G5TDO/G5TBO))
CRANK	MATERIAL	Forged Alloy-6061-T6	Forged Alloy-6061-T6	Forged Alloy-6061-T6	Steel
	LENGTH	165,170mm	165,170mm	170,175mm	140,152,165,170mm
CHAINRINGS	GEAR	3/32" 44T	1/8" 44T 48T	3/32" 52T	3/32" 52T
	MATERIAL	3.0mm Alloy	3.0mm Alloy 100% CNC	Steel	Steel
PCD		/	144mm	/	/
CHAINGUAED COVER		2.0mm Alloy	/	Double Plastic	Double Plastic
CHAIN LINE		45.5mm	46.5mm	45mm	45mm
B.B.AXLE		108mm	108mm	117.5mm	117.5mm

公路车

公路车

公路车

城市车

折叠车

儿童车





**SPB5B-MX4**

( SPB5B-MX4(G5QDO/I) )



**SPB5B-ME**

( SPB5B-ME(G5TFO/G5TDI) )



**TOP-S046**

( SOF5F-MGC(G5QBO/I) )



**TOP-B48**

( SXF8H(MGC(G4FAO/GFLI) )



**SPBAB-MGB**

( SPBAB-MGB(G5QA0/I) )



**TOP-A44**

( SPF4T-MGC(G4XZO/I) )



**TOP-46PP**

( SPBAB-RF5(G5YDO/I) )

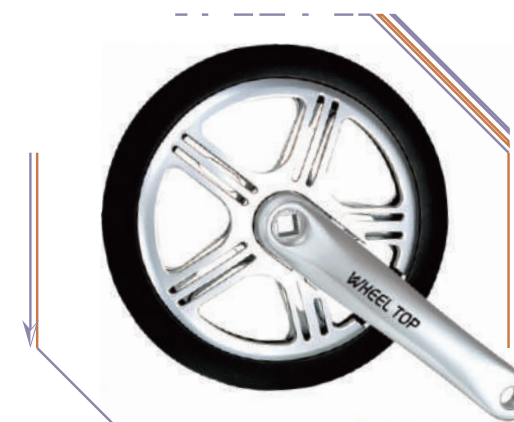

**TOP-GK5H**

( SOB5B-MGC(GK5H) )

MODEL		SPB5B-MX4 (SPB5B-MX4(G5QDO/I))	SPBAB-ME (SPBAB-ME(G5TFO/G5TDI))	SPBAB-MGB (SPBAB-MGB(G5QA0/I))	TOP-A44 (SPF4T-MGC(G4XZO/I))
CRANK	MATERIAL	Forged Alloy-6061-T6	Forged Alloy-6061-T6	Forged Alloy-6061-T6	Forged Alloy-6061-T6
	LENGTH	165,170mm	152,160,165,170mm	165mm	165,170mm
CHAINRINGS	GEAR	3/32" 44T 46T	3/32" 48T	3/32" 46T	3/32" 44T
	MATERIAL	Steel	Steel	Steel	Steel
CHAINGUAED COVER		Double Plastic	Double Plastic	Double Plastic	Double Plastic
CHAIN LINE		45mm	45mm	45mm	45mm
B.B.AXLE		117.5mm	117.5mm	117.5mm	127.5mm

MODEL		TOP-S046 (SOF5F-MGC(G5QBO/I))	TOP-B48 (SXF8H-MGC(G4FAO/GFLI))	TOP-46PP (SPBAB-RF5(G5YDO/I))	TOP-GK5H (SOB5B-MGC(GK5H))
CRANK	MATERIAL	Forged Alloy-6061-T6	Forged Alloy-6061-T6	Forged Alloy-6061-T6	Forged Alloy-6061-T6
	LENGTH	170mm	165,170mm	165,170mm	165,170mm
CHAINRINGS	GEAR	1/8" 46T	3/32" 36T 46T 48T	3/32" 46T	1/8" 48T
	MATERIAL	Steel	Steel	Steel	Steel
CHAINGUAED COVER		Double Plastic	Double Plastic	Double Plastic	Single Plastic Combination
CHAIN LINE		45mm	45mm	45mm	45mm
B.B.AXLE		127.5mm	127.5mm	117.5mm	117.5mm

公路车

山地车

城市车

折叠车

儿童车





**TOP-GK5F**  
( SPB5B-MGC(GK5F/G5TDI) )



**SOF8H-MTT**  
( SOF8H-MTT(G4FAO) )



**SPB5B-MT**  
( SPB5B-MT(G5TDO/G5TBO) )



**SPBAB-ME**  
( SPBAB-ME(G5TDO) )



**SIC2F-10P-MGB**  
( SIC2F10P-MGB(G5BTO) )



**SXBAB-YBT**  
( SXBAB-YBT(G5QDO/I) )



**SPBAB-MT**  
( SPBAB-MT(G5TDO/I) )

MODEL		TOP-GK5F (SPB5B-MGC(GK5F/G5TDI))	SPBAB-ME (SPBAB-ME(G5TDO))	SIC2F-10P-MGB (SIC2F10P-MGB(G5BTO))
CRANK	MATERIAL	Forged Alloy-6061-T6	Forged Alloy-6061-T6	Forged Alloy-6061-T6
	LENGTH	165,170mm	152,165,170mm	140,152,165,170mm
CHAINRINGS	GEAR	3/32" 48T	3/32" 48T	3/32" 42T
	MATERIAL	Steel	Steel	Steel
CHAINGUAED COVER		Double Plastic	Plastic	Single Plastic
CHAIN LINE		45mm	45mm	45mm
B.B.AXLE		117.5mm	117.5mm	120mm

MODEL		SOF8H-MTT (SOF8H-MTT(G4FAO))	SPB5B-MT (SPB5B-MT(G5TDO/G5TBO))	SXBAB-YBT (SXBAB-YBT(G5QDO/I))	SPBAB-MT (SPBAB-MT(G5TDO/I))
CRANK	MATERIAL	Steel	Steel	Forged Steel	Steel
	LENGTH	165,170mm	152,160,165,170mm	152,165,170mm	140,152,165,170mm
CHAINRINGS	GEAR	1/8" 48T	3/32" 52T	3/32" 44T	3/32" 46T
	MATERIAL	Steel	Steel	Steel	Steel
PCD		/	/	/	/
CHAINGUAED COVER		Plastic	Double Plastic	Double Plastic	Double Plastic
CHAIN LINE		48mm	45mm	45mm	45mm
B.B.AXLE		126mm	117.5mm	116mm	117.5mm

公路车

公路车

公路车

城市车

折叠车

儿童车





**DIAMOND-ICK**  
( SIC2F6P-ICK(G5PXK) )



**DIAMOND-ICZ**  
( SIC2F6P-ICZ(G5PXC) )

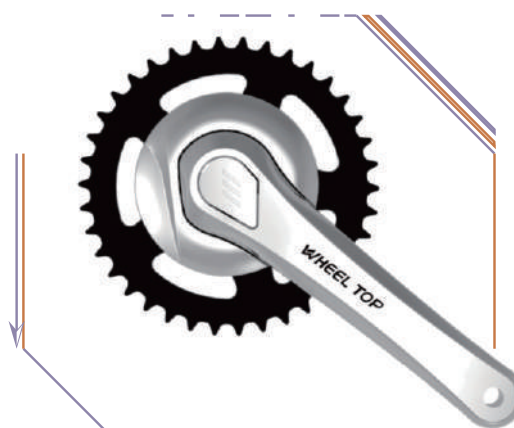

**DIAMOND-ICM**  
( SIC2F6P-ICM(G5PXM) )



**DIAMOND-ICB**  
( SIC2F6P-ICB(PIC) )

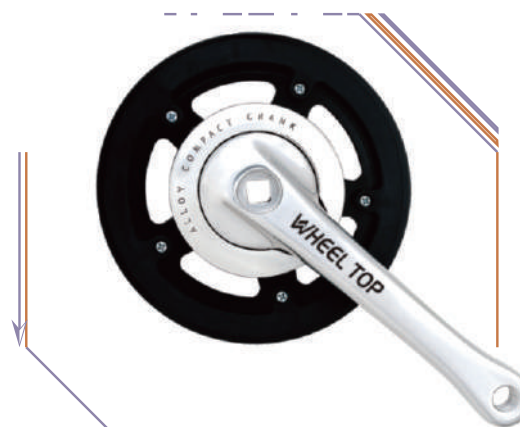

**DIAMOND-ICBPP**  
( SIC2F6P-ICK(G5BRO/I)(PIC) )



**DIAMOND-ICF**  
( SIC2F6P-ICF(G5PXC) )



**DIAMOND-ICT**  
( SIC2F6P-ICT(G5PCT) )



**DIAMOND-100B**  
( SXF6H-CFPH(10GA) )

MODEL		DIAMOND-ICK (SIC2F6P-ICK(G5PXK))	DIAMOND-ICZ (SIC2F6P-ICZ(G5PXC))	DIAMOND-ICBPP (SIC2F6P-ICB(G5BRO/I)(PIC))	DIAMOND-ICF (SIC2F6P-ICF(G5PXC))
CRANK	MATERIAL	Forged Alloy-6061	Forged Alloy-6061-T6	Forged Alloy-6061-T6	Forged Alloy-6061-T6
	LENGTH	170mm	170mm	165,170mm	165,170mm
CHAINRINGS	GEAR	3/32" 38T 42T 44T	3/32" 38T 42T 44T	3/32" 38T	3/32" 38T 42T 44T
	MATERIAL	Steel	Steel	Steel	Steel
CHAINGUAED COVER		Steel DIA95	Plastic DIA95	Double Plastic/Plastic DIA95	Plastic DIA95
CHAIN LINE		45mm	45mm	45mm	45mm
B.B.AXLE		120mm	120mm	120mm	120mm

MODEL		DIAMOND-ICM (SIC2F6P-ICM(G5PXM))	DIAMOND-ICB (SIC2F6P-ICB(PIC))	DIAMOND-ICT (SIC2F6P-ICT(G5PCT))	DIAMOND-100B (SXF6H-CFPH(10GA))
CRANK	MATERIAL	Forged Alloy-6061-T6	Forged Alloy-6061-T6	Forged Alloy-6061-T6	Plastic Coated Steel
	LENGTH	170mm	165,170mm	170mm	170mm
CHAINRINGS	GEAR	3/32" 38T 42T	3/32" 38T 42T 44T 46T	3/32" 38T 42T	3/32" 38T
	MATERIAL	Steel	Steel	Steel	Steel
CHAINGUAED COVER		Plastic DIA95	Plastic DIA95	Plastic DIA95	Plastic DIA95
CHAIN LINE		45mm	45mm	45mm	45mm
B.B.AXLE		120mm	120mm	120mm	119mm

公路车

山地车

城市车

折叠车

儿童车





**TOP-X40**  
( SIC2F6P-ST1(G5ST) )



**SIC2F30-MGB**  
( SIC2F30-MGB(GK3F110) )



**TOP-GK3Y**  
( SOD3H-ME(GK3Y) )



**TOP-G3CK**  
( SIC2F3P-ME(GG3CK) )



**SOD3H-MT**  
( SOD3H-MT(GK2F) )



**SOD3H-YBT**  
( SOD3H-YBT(G3CK) )

MODEL		TOP-X40 (SIC2F6P-ST1(G5ST))	TOP-GK3Y (SOD3H-ME(GK3Y))	TOP-G3CK (SIC2F3P-ME(GG3CK))
CRANK	MATERIAL	Forged Alloy-6061-T6	Forged Alloy-6061-T6	Forged Alloy-6061-T6
	LENGTH	160,165,170mm	152,160,165,170mm	152,160,165,170mm
CHAINRINGS	GEAR	3/32" 40T 44T 46T	1/8" 38T	3/32" 33T 36T
	MATERIAL	Steel	Steel	Steel
CHAINGUAED COVER		Plastic DIA95	Plastic DIA95	Plastic DIA95,110
CHAIN LINE		45mm	45mm	45mm
B.B.AXLE		120mm	120mm	120mm

MODEL		SIC2F30-MGB (SIC2F30-MGB(GK3F110))	SOD3H-MT (SOD3H-MT(GK2F))	SOD3H-YBT (SOD3H-YBT(G3CK))
CRANK	MATERIAL	Forged Alloy-6061-T6	Steel	Steel
	LENGTH	165,170,175mm	140,152,165,170mm	127,140,152,160,165,170mm
CHAINRINGS	GEAR	1/8" 36T	1/8" 33T 36T	1/8" 33T 36T
	MATERIAL	Steel	Steel	Steel
CHAINGUAED COVER		Plastic DIA110	Plastic	Single Plastic
CHAIN LINE		45mm	45mm	45mm
B.B.AXLE		120mm	120mm	117.5mm

公路车

公路车

山地车

城市车

折叠车

儿童车



**TOP-Y42S**

( SPC3J-YBT(GK2F) )

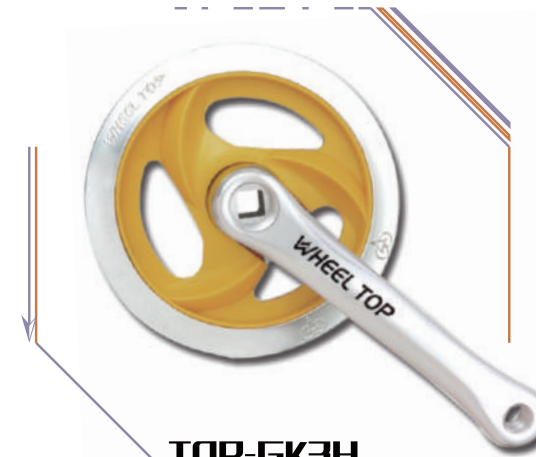
**TOP-GK3H**

( SRT3F-MS(GK3H/G3KFI) )

**TOP-G5KP**

( SKD5F-MS(G5KPO/G5CTI) )

**TOP-G5KJ**

( SKD5F-MGB(G5KJO/G5CTI) )

**TOP-P36**

( SRF4F-MS(G4ADO/I) )

**TOP-H36**

( SKD5F-MGB(G5KDO/G5CTI) )

MODEL		TOP-Y42S (SPC3J-YBT(GK2F))	TOP-G5KP (SKD5F-MS(G5KPO/G5CTI))	TOP-G5KJ (SKD5F-MGB(G5KJO/G5CTI))
CRANK	MATERIAL	Forged Steel	Forged Alloy-6061-T6	Forged Alloy-6061-T6
	LENGTH	152,165,170mm	152,165,170mm	152,165,170mm
CHAINRINGS	GEAR	3/32" 42T	3/32" 36T	3/32" 36T
	MATERIAL	Steel	Steel	Steel
PCD		/	/	/
CHAINGUAED COVER		Plastic DIA95	Double Plastic Combination	Double Plastic Combination
CHAIN LINE		45mm	45mm	45mm
B.B.AXLE		117.5mm	117.5mm	127.5mm

MODEL		TOP-GK3H (SRT3F-MS(GK3H/G3KFI))	TOP-P36 (SRF4F-MS(G4ADO/I))	TOP-H36 (SKD5F-MGB(G5KDO/G5CTI))
CRANK	MATERIAL	Forged Alloy-6061-T6	Forged Alloy-6061-T6	Forged Alloy-6061-T6
	LENGTH	152,165,170mm	152,165,170mm	140,152,165,170mm
CHAINRINGS	GEAR	3/32" 36T	3/32" 36T	3/32" 36T
	MATERIAL	Steel	Steel	Steel
CHAINGUAED COVER		Double Plastic Combination	Double Plastic	Double Plastic
CHAIN LINE		45mm	45mm	45mm
B.B.AXLE		127.5mm	127.5mm	127.5mm

公路车

公路车

公路车

城市车

折叠车

儿童车



**TOP-K36**

( SRF3F-MGB(G3ACO/I) )

**TOP-Q36**

( SPF5F-MS(G5QCO/I) )

**TOP-M36**

( SKD5F-MGB(G5KHO/G5KFI) )

**TOP-G5KE**

( SKD5F-MGB(G5KEO/G5CTI) )

**TOP-I36**

( SPF5F-MGB(G5AEO/G5CTI) )

**TOP-N36**

( SPF5T-MS(PGO/I) )

MODEL		TOP-K36 (SRF3F-MGB(G3ACO/I))	TOP-M36 (SKD5F-MGB(G5KHO/G5KFI))	TOP-G5KE (SKD5F-MGB(G5KEO/G5CTI))
CRANK	MATERIAL	Forged Alloy-6061-T6	Forged Alloy-6061-T6	Forged Alloy-6061-T6
	LENGTH	140,152,165,170mm	140,152,165,170mm	140,152,165,170mm
CHAINRINGS	GEAR	3/32" 36T 40T	3/32" 36T	3/32" 36T
	MATERIAL	Steel	Steel	Steel
CHAINGUAED COVER		Double Plastic	Double Plastic	Double Plastic
CHAIN LINE		45mm	45mm	45mm
B.B.AXLE		127.5mm	127.5mm	127.5mm

MODEL		TOP-Q36 (SPF5F-MS(G5QCO/I))	TOP-I36 (SPF5F-MGB(G5AEO/G5CTI))	TOP-N36 (SPF5T-MS(PGO/I))
CRANK	MATERIAL	Forged Alloy-6061-T6	Forged Alloy-6061-T6	Forged Alloy-6061-T6
	LENGTH	152,165,170mm	140,152,165,170mm	152,165,170mm
CHAINRINGS	GEAR	3/32" 36T 40T	3/32" 36T	3/32" 36T 40T
	MATERIAL	Steel	Steel	Steel
CHAINGUAED COVER		Double Plastic	Double Plastic	Double Plastic
CHAIN LINE		45mm	45mm	45mm
B.B.AXLE		127.5mm	127.5mm	127.5mm

公路车

公路车

山地车

城市车

折叠车

儿童车



**SKD5F-MS**

( SKD5F-MS(G5JTO/G5CTI) )

**SIC2F10P-ME**

( SIC2F10P-ME(G5TDO/I) )

**SKD5F-YBT**

( SKD5F-YBT(G5AYO) )

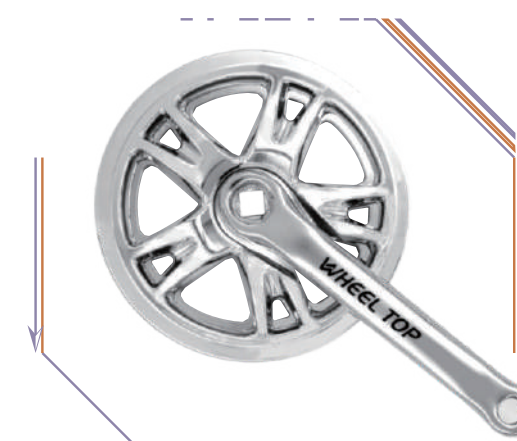
**SKD5F-YBT-1**

( SKD5F-YBT-1(G5KHO/G5KFI) )

**TOP-PD**

( SPD4H-CFPC(G4PD) )

**SRF4F-YBT**

( SRF4F-YBT(G4ADO/I) )

**SKD3F-YBT**

( SKD3F-YBT(G3AFO/G3KDI) )

**SPB5B-Y**

( SPB5B-Y(GAO/I) )

MODEL		SKD5F-MS (SKD5F-MS(G5JTO/G5CTI))	SIC2F10P-ME (G5TDO/I)	TOP-PD (SPD4H-CFPC(G4PD))	SRF4F-YBT (SRF4F-YBT(G4ADO/I))
CRANK	MATERIAL	Forged Alloy-6061-T6	Forged Alloy-6061-T6	Forged Alloy-6061-T6	Forged Alloy-6061-T6
	LENGTH	152,165,170mm	152,160,165,170mm	140mm	127,140,152,160,165,170mm
CHAINRINGS	GEAR	3/32" 36T	3/32" 36T 40T	3/32" 36T	3/32" 44T
	MATERIAL	Steel	Steel	Steel	Steel
CHAINGUAED COVER		Double Plastic	Double Plastic	Single Plastic	Double Plastic
CHAIN LINE		45mm	45mm	45mm	45mm
B.B.AXLE		127.5mm	120mm	119mm	126mm

MODEL		SKD5F-YBT (SKD5F-YBT(G5AYO))	SKD5F-YBT-1 (SKD5F-YBT-1(G5KHO/G5KFI))	SKD3F-YBT (SKD3F-YBT(G3AFO/G3KDI))	SPB5B-Y (SPB5B-Y(GAO/I))
CRANK	MATERIAL	Forged Steel	Steel	Steel	Steel
	LENGTH	152,165,170mm	127,140,150,160,165mm	127,140,150,160,165mm	127,140,150,160,165mm
CHAINRINGS	GEAR	3/32" 36T	3/32" 36T	3/32" 36T	3/32" 40T
	MATERIAL	Steel	Steel	Steel	Steel
CHAINGUAED COVER		Single Plastic	Double Plastic	Double Plastic	Single Plastic Combination
CHAIN LINE		45mm	45mm	45mm	45mm
B.B.AXLE		127.5mm	126mm	126mm	116mm

公路车

公路车

公路车

城市车

折叠车

儿童车





**SPD4H-YBT**  
( SPD4H-YBT(G4PDO/I) )



**SPE4H-RF5**



**SPF5H-YBT**  
( SPF5H-YBT(PEO/PGI) )



**SPD4H-YBT**  
( SPD4H-YBT(G4PEO/G4PDI) )



**TOP-32T**  
( SOF5H-RF5 )



**SOF5H-MS**

MODEL		SPD4H-YBT (SPD4H-YBT(G4PDO/I))	SPF5H-YBT (SPF5H-YBT(PEO/PGI))	SPD4H-YBT (SPD4H-YBT(G4PEO/G4PDI))
CRANK	MATERIAL	Steel	Steel	Steel
	LENGTH	127,140,152,160,165mm	127,140,152,160,165,170mm	140,152,160,165,170mm
CHAINRINGS	GEAR	3/32" 36T 38T 40T	3/32" 32T 33T	3/32" 36T
	MATERIAL	Steel	Steel	Steel
CHAINGUAED COVER		Double Plastic	Double Plastic	Double Plastic
CHAIN LINE		45mm	45mm	45mm
B.B.AXLE		117.5mm	126mm	117.5mm

MODEL		SPE4H-RF5	TOP-32T (SOF5H-RF5)	SOF5H-MS
CRANK	MATERIAL	Forged Alloy-6061-T6	Forged Alloy-6061-T6	Forged Alloy-6061-T6
	LENGTH	165,170mm	165,170mm	127,140,152,160,165,170mm
CHAINRINGS	GEAR	3/32" 42T	1/8" 30T 31T 32T 33T 34T 36T 38T 40T	1/8" 28T 30T 31T 32T 33T 34T 36T 38T 48T
	MATERIAL	Steel	Steel	Steel
CHAINGUAED COVER		/	/	/
CHAIN LINE		45mm	45mm	45mm
B.B.AXLE		126mm	127.5mm	129mm

公路车  
山地车  
城市车  
折叠车  
儿童车





公路车  
山地车  
城市车  
折叠车  
儿童车

MODEL		SOF5H-YBT	SPB4B-MZ	TOP-MT (SIC3F10P-MT)
CRANK	MATERIAL	Steel	Steel	Forged Steel
	LENGTH	127,140,152,160,165mm	140,152,165,170mm	140,152,165,170mm
CHAINRINGS	GEAR	1/8" 30T 31T 32T 33T 34T 36T 38T 40T	3/32" 42T	3/32" 38T 42T
	MATERIAL	Steel	Steel	Steel
CHAINGUAED COVER		/	/	/
CHAIN LINE		45mm	45mm	45mm
B.B.AXLE		117.5mm	117.5mm	120mm

MODEL		TOP-MZ (SRF4F-MZ)	Y-32T (SOF5H-Y)
CRANK	MATERIAL	Forged Steel	Forged Steel
	LENGTH	140,152,165,170mm	127,140,152,165,170mm
CHAINRINGS	GEAR	3/32" 36T 40T	1/8" 30T 31T 32T 33T 34T 36T 38T 40T
	MATERIAL	Steel	Steel
CHAINGUAED COVER		/	/
CHAIN LINE		45mm	45mm
B.B.AXLE		127.5mm	126mm



A young boy with short blonde hair, wearing a red and white striped sweater and light blue pants, is riding a black bicycle on a paved path. The path is surrounded by lush green grass and trees with dense foliage. In the background, a person is visible near a building entrance. The scene is captured from a rear perspective, showing the boy's back and the bicycle's rear wheel and seat.

# KIDS 儿童车





**SXB4BL-WM**  
( SXB4BL-WM(G4PDO/I) )



**SXB4BL-MS**  
( SXB4BL-MS(G4PDO/I) )



**SPF5H-SH**  
( SPF5H-SH(PEO) )



**TOP-MB**  
( SOF4H-MB )



**SPB4B-MS**  
( SPB4B-MS(G4PDO) )



**SPF5H-MS**  
( SPF5H-MS(PEO/PGI) )



**SPF5H-MZ**  
( SPF5H-MZ(PEO/PGI) )



**SOFOH-Y**

MODEL		SXB4BL-WM (SXB4BL-WM(G4PDO/I))	SXB4BL-MS (SXB4BL-MS(G4PDO/I))	SPB4B-MS (SPB4B-MGB(G4PDO))	SPF5H-MS (SPF5H-MS(PEO/PGI))
CRANK	MATERIAL	Forged Alloy-6061-T6	Forged Alloy-6061-T6	Forged Alloy-6061-T6	Forged Alloy-6061-T6
	LENGTH	127,140,160mm	89,102,114,127mm	89,102,114,127mm	89,102,114,127mm
CHAINRINGS	GEAR	3/32" 28T 32T	3/32" 32T 28T	3/32" 28T	3/32" 32T
	MATERIAL	Alloy	Alloy	Steel	Steel
CHAINGUAED COVER		Double Plastic	Double Plastic	Plastic	Double Plastic
CHAIN LINE		45mm	45mm	45mm	45mm
B.B.AXLE		116mm	117.5mm	117.5m	126mm

MODEL		SPF5H-SH (SPF5H-SH(PEO))	TOP-MB (SOF4H-MB)	SPF5H-MZ (SPF5H-MZ(PEO/PGI))	SOFOH-Y
CRANK	MATERIAL	Forged Alloy-6061-T6	Forged Alloy-6061-T6	Steel	Steel
	LENGTH	127/152mm	70,89,140mm	120/140mm	89,102,114,127mm
CHAINRINGS	GEAR	3/32" 32T	3/32" 38T 42T 44T	3/32" 24T 28T	1/8" 28T 32T
	MATERIAL	Steel	Steel	Steel	Steel
CHAINGUAED COVER		Plastic		Double Plastic	/
CHAIN LINE		45mm	45mm	45mm	45mm
B.B.AXLE		129mm	129mm	126mm	126mm

公路车

山地车

儿童车

折叠车

电动自行车

儿童车





# KIDS



**SPF4H-KT**



**NEW SPB4B85S-TC**  
( SPB4B85S-TC(85GA) )



**TOP-Y**  
( SOF4H-Y )

MODEL		SPF4H-KT	SPB4B85S-TC	TOP-Y (SOF4H-Y)
CRANK	MATERIAL	Steel	Forged Alloy-6061-T6	Forged Steel
	LENGTH	89,102,114mm	89,102,114,120,127mm	89,102,114,127mm
CHAINRINGS	GEAR	3/32" 28T 32T	3/32"28T 32T	1/8" 24T 28T
	MATERIAL	Steel	Steel	Steel
CHAINGUAED COVER		/	Plastic	/
CHAIN LINE		45mm	45mm	45mm
B.B.AXLE		126mm	126mm	126mm



CRANK SET

E-BIKE PART

BELT PULLEY

NEW GB

DERAILLEUR

ED5



105T

24T

28T

32T

36T

40T





## 2-PCS命名规则 2 - PCS Naming Conventions

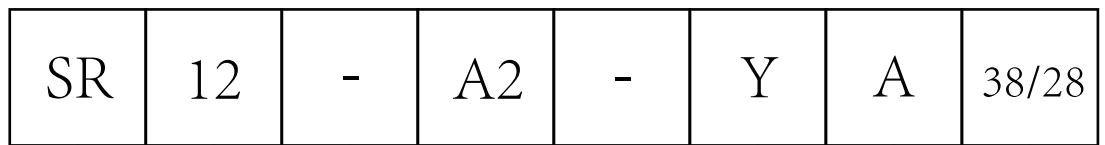

SR 类别名 (HR、CR、SR、SAGE、GA、AIR)  
 12 序号  
 - 固定符号 (一个字符)  
 A2 结合模式/BCD和可装牙盘层数 (分锁类: A-104, G-96 (96/64), B-104/64, C-110, S-130, Z-中锁, X-SRAM通用GXP规格/3螺丝, M-铆合。数字几表示可装牙盘层数几)  
 - 固定符号 (一个字符)  
 Y 右曲柄花键: 通孔盲孔区别 (Y-通孔, W-盲孔)  
 A 牙盘材质 (A-铝, S-钢, B-包塑)  
 38/28 齿数

曲柄分类细则	
名称	类别
HR	2-PCS
CR	单曲柄, 带爪
SR	2-PCS
SAGE	公路车系列
GA	Grand, 混合越野公路车
AIR	超轻系列、中空

## 标注示例 Labeling Examples

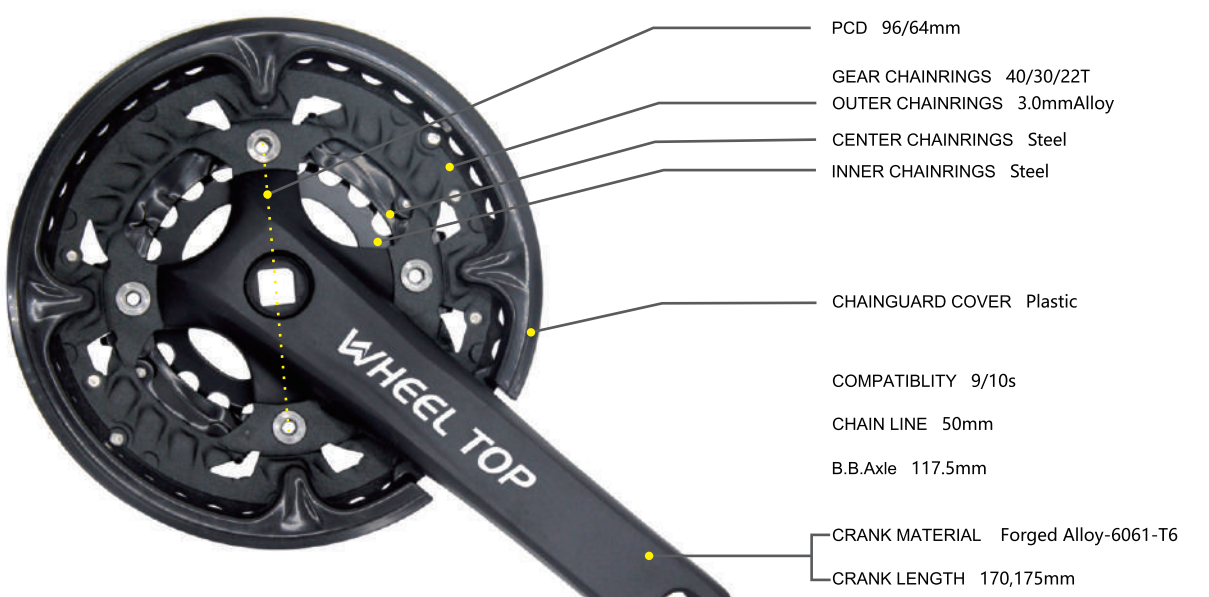

**TCXC2L-HF1**  
(TCXC2L-HF1(G4SE))

## 表面处理说明

- AA (抛光本色氧化) -POLISHED ANODIZED
- AB (抛光震动本色氧化) -VIBRATED POLISHED ANODIZED
- HA (喷砂本色氧化) -SILVER SAND ANODIZED
- HBK (喷砂黑色氧化) -BLACK SAND ANODIZED
- HBS (喷砂正面抛光黑色氧化) -BLACK SANDED WITH FRONT-POLISHED ANODIZED
- DBK (亚光黑色电泳) -MATT BLACK ELECTROPHORESIS
- BED (黑色抛光电泳) -BLACK POLISHED ELECTROPHORESIS
- CP (电镀) -CHROME PLATING
- ED (电泳) -ELECTROPHORESIS
- SL (烤漆) -SILVER PAINTED
- PS (抛光+喷砂复合) -POLISH&SANDING



DCRX1-SMA(G4FE)(LFE46)  
 塑罩、塑爪型号 CHAINGUARD、COVER  
 曲柄型号 CRANK  
 链轮型号 CHAINRING







### ONE-PCS CRANK



LTS

BIG ROUND  
MID ROUND

SIZE:89;102;114;127;  
140;152;165;170;175;

THREAD:B15/16"-24-R  
B7/8:-24-L



LT

Big 6 Square  
Mid 6 Square

SIZE:89;102;114;127;  
140;152;165;170;175;

THREAD:B15/16"-24-R  
B7/8:-24-L



BMX

SIZE: 140; 152; 165;  
THREAD:B15/16"24R  
B7/8:24L



Kids-FOA

SIZE: 89; 102; 114;  
THREAD:B15/16"-24-R  
B7/8:-24-L

### 螺栓型式中轴尺寸

#### BOLT TYPE AXLE DIMENSIONS

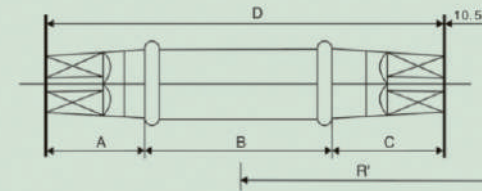

### 螺母型式中轴尺寸

#### NUT TYPE AXLE DIMENSIONS

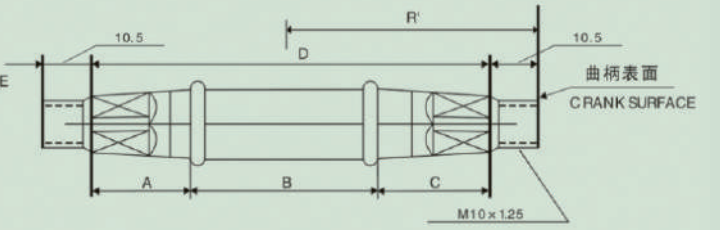

### BOLT&NUT TYPE

B.B.WIDTH	MODEL	A	B	C	D	R'	B.B.WIDTH	MODEL	A	B	C	D	R'
68	3EB	30.5	52	28	110.5	64.5	68	3M	28	52	28	108	64.5
	3CB			32	114.5	68.5		3K	29		29	110	65.5
	3HB			30.5	113	67		3H	30.5		30.5	113	67
	3JB	31		115	67.5	3L		32	32		116	68.5	
	3LB	32		116	68.5	3A			33.5		117.5	70	
	3AB	33.5		117.5	70	3P		35	119		71.5		
	3PB	35		119	71.5	3N		36	120		72.5		
	3NB	36		120	72.5	3SS		37.5	121.5		74		
	3SSB	37.5		121.5	74	3Z		33.5	33.5		119	70	
	3PLB	35		122	71.5	3PL		35	35		122	71.5	
	3SB	37.5		124.5	74	3S			37.5		124.5	74	
	3TB	39		126	75.5	3T		39	126		75.5		
	3UB	40.5		127.5	77	3U		40.5	127.5		77		
	3RB	42		129	78.5	3R		42	129		78.5		
70	5BB	30	55	33.5	118.5	71.5	70	5B	30	55	33.5	118.5	71.5
	5LB	32		30	117	68		5L	30		117	68	
	5PB	35		35	122	73		5P	32		35	122	73
	5SB	37.5		127.5	75.5	5S		37.5	127.5		75.5		
	5TB	39		129	77	5T		35	39		129	77	

### 配图一体式中轴尺寸

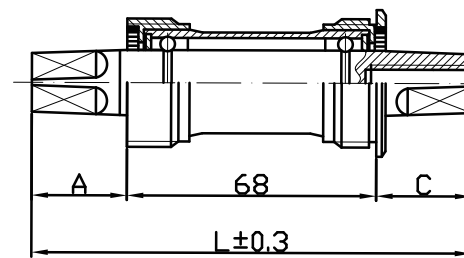

Bracket Width	68	68	68	68	68	68
A	32	27	26.5	27	26.5	24.5
C	37	32.5	31.5	29.5	28	27.5
Axle Length	137	127.5	126	124.5	122.5	120
Bracket Width	68	68	68	68	68	68
A	23.5	22.5	23	21.5	21.5	18
C	26.5	25.5	24	23.5	21	21
Axle Length	118	116	115	113	110.5	107





CRANK SET

E-BIKE

BELT PULLY

NEW GB

DERAILLEUR

EDS





## DERAILLEUR 变速器

### FD-TM100 前拨

- 1.High Strength Alloy Steel
- 2.Compatible Chainring: 42/34/24T;
- 3.Chain Line: 48~51.5mm;
- 4.Cable Route Type /UP-Pell/POW-Pull;
- 5.Mount/CLAMP BAND(mm):  
Φ28.6mm,Φ31.8mm,Φ34.9mm.
- 6.Chain Stay Angle: 66~69°;
- 7.Total Capacity: 18T;

- 1.高强度合金钢;
- 2.适配牙盘42/34/24T;
- 3.链线: 48~51.5mm;
- 4.上拉, 下拉可选;
- 5.安装夹环直径:  
Φ28.6mm,Φ31.8mm,Φ34.9mm可选。
- 6.安装角度: 66~69°;
- 7.齿容量: 18T;



### FD-TM200 前拨

- 1.High Strength Alloy Steel
- 2.Compatible Chainring: 42/34/24T;
- 3.Chain Line: 48~51.5mm;
- 4.Cable Route Type/Dual-Pull;
- 5.Mount/CLAMP BAND(mm):  
Φ31.8mm,Φ34.9mm.
- 6.Chain Stay Angle: 66~69°;
- 7.Total Capacity: 18T;

- 1.高强度合金钢;
- 2.适配牙盘42/34/24T;
- 3.链线: 48~51.5mm;
- 4.拉线方式: 双拉;
- 5.安装夹环直径:  
Φ31.8mm,Φ34.9mm可选。
- 6.安装角度: 66~69°;
- 7.齿容量: 18T;



### SL-TM200 转把

- 1.Model No.: SL-TM200,SL-TM250
- 2.Front Speeds: 3S  
Rear Speeds: 6S, 7S;
- 3.High Strength Composite;
- 4.Shifting Smoothly&Rapidly

- 1.转把SL-TM200,SL-TM250两型号可选; 2.可循
- 2.3S,6S,7S可选;
- 3.高强度复合材料;
- 4.档位清晰, 顺畅。



## DERAILLEUR 变速器

### RD-TM200 后拨

- 1.High Strength Composite;;
- 2.Compatible Cassette: 14~28T;
- 3.Tatal Capacity: 32T;
- 4.Cage Length: Short/Meniun;

- 1.高强度复合材料;
- 2.适配飞轮14~28T;
- 3.最大容齿量: 32T;
- 4.腿长: 短腿, 中腿可选;



### RD-TM350 后拨

- 1.High Strength Composite;
- 2.Compatible Cassette: 11~36T;
- 3.Tatal Capacity: 43T;
- 4.Cage Length: Short/Meniun;
- 5.Compatible With Shiamno

- 1.高强度铝合金材料;
- 2.适配飞轮11~36T;
- 3.最大容齿量: 43T;
- 4.腿长: 中腿, 长腿可选;
- 5.兼容Shiamno



### SL-TM300 指拨

- 1.Front Speeds: 3S  
Rear Speeds: 6S, 7S; ;
- 2.Visual Gear Inoicator;
- 3.High Strength Composite;;
- 4.Shifting Smoothly&Rapidly.

- 1.3S,6S,7S可选;
- 2.带视窗;
- 3.高强度复合材料;
- 4.档位清晰, 顺畅。



### SL-TM350 指拨

- 1.Front Speeds: 3S  
Rear Speeds: 6S, 7S, 9S;
- 2.Visual Gear Inoicator;
- 3.High Strength Alloy Clamp;
- 4.Shifting Smoothly&Rapidly;
- 5.Compatible With Shiamno

- 1.3S,7S,8S, 9S可选;
- 2.带视窗;
- 3.高强度铝合金固定环;
- 4.档位清晰, 顺畅。
- 5.兼容Shiamno





A close-up photograph of the rear drivetrain of a bicycle. The frame is a vibrant orange color. The rear wheel has a silver-colored cassette with multiple gears. A black rear derailleur is mounted on the frame, and a silver chain is visible. A black crankset is partially visible on the left. The background is dark, making the components stand out. Labels with leader lines point to various parts: 'CRANK SET', 'E-BIKE', 'BELT PULLY', 'NEW GB', 'DERAILLEUR', and 'EDS'.

CRANK SET

E-BIKE

BELT PULLY

NEW GB

DERAILLEUR

EDS





## 公路飞轮

### CS-TR9000

速别：13速  
 齿数：11-32T、11-34T、11-36T  
 颜色：银色  
 设计：全新外观设计，变速能力顺滑、稳定



### CS-TR8000

型号：CS-TR8000  
 速别：12速  
 齿数：11-32T、11-34T、11-36T  
 颜色：银色  
 设计：全新外观设计，变速能力顺滑、稳定



### CS-TR8500

速别：12速  
 齿数：11-32T、11-34T、11-36T  
 颜色：银色、黑色、炫彩  
 设计：CNC一体镂空，轻便性能两不误



### CS-TR7000

速别：11速  
 齿数：11-25T、11-28T、11-30T、11-32T  
 颜色：炫彩、银色  
 设计：全新外观设计，变速能力顺滑、稳定

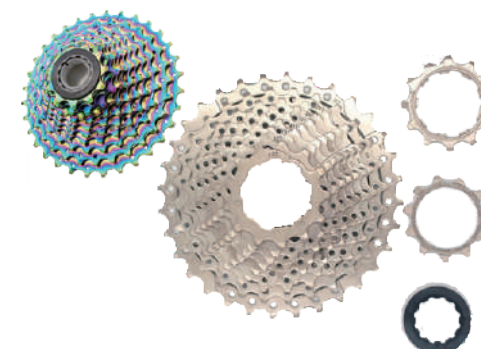

### CS-TR7500

速别：11速  
 齿数：11-25T、11-28T、11-32T、11-34T  
 颜色：金色、银色、黑色、炫彩  
 设计：CNC一体镂空，轻便性能两不误



### CS-TR6000

型号：CS-TR6000  
 速别：10速  
 齿数：11-28T、11-32T、11-34T  
 颜色：炫彩、银色  
 设计：全新外观设计，变速能力顺滑、稳定







飞轮

## 公路飞轮

### CS-TR5000

速别：9速  
齿数：11-23T、11-25T、11-36T  
颜色：炫彩、银色  
设计：全新外观设计，变速能力顺滑、稳定

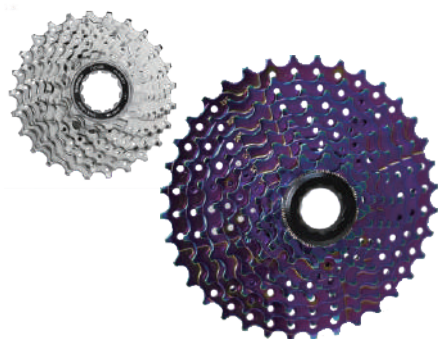

### CS-TR4000

速别：8速  
齿数：11-28T、11-30T、11-32T  
颜色：银色  
设计：全新外观设计，变速能力顺滑、稳定



### CS-TR3000

速别：7速  
齿数：12-28T  
颜色：银色  
设计：全新外观设计，变速能力顺滑、稳定



CRANK  
SET

E-BIKE  
PART

BELT  
PULLEY

NEW GB

DERAILLEUR

ED5

### CS-TM9000

速别：13速  
齿数：11-50T、11-52T  
颜色：银色  
设计：全新外观设计，变速能力顺滑、稳定



### CS-TM8000

速别：12速  
齿数：11-46T、11-50T、11-52T  
颜色：银色  
设计：全新外观设计，变速能力顺滑、稳定



### CS-TM8500

速别：12速  
齿数：11-50T  
颜色：金色、银色、黑色、炫彩  
设计：CNC一体镂空，轻便性能双不误

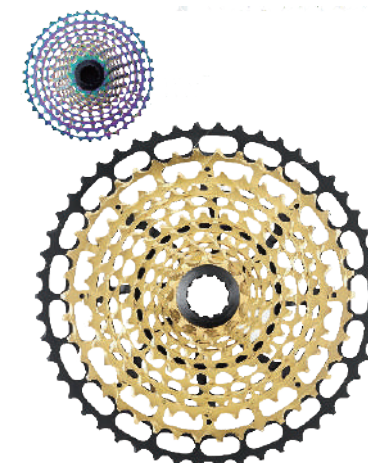





## 公路飞轮

### CS-TM7000

速别：11速  
 齿数：11-36T、11-40T、11-42T、11-46T、  
 11-50T、11-52T  
 重量：600g  
 颜色：银色  
 设计：全新外观设计，变速能力顺滑、稳定



### CS-TM7500

速别：11速  
 齿数：10-42T、11-42T、11-52T  
 颜色：金色、银色、黑色、炫彩  
 设计：CNC一体镂空，轻便性能两不误

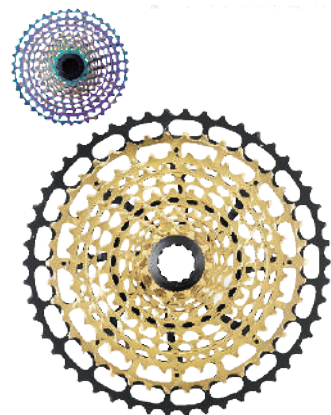

### CS-TM6000

速别：10速  
 齿数：11-30T、11-34T、11-36T、11-40T、  
 11-42T、11-46T、11-50T  
 颜色：银色  
 设计：全新外观设计，变速能力顺滑、稳定



### 型号：CS-TM5000

速别：9速  
 齿数：11-32T 11-36T 11-40T 11-42T 11-46T 11-50T  
 颜色：银色  
 设计：全新外观设计，变速能力顺滑、稳定



### 型号：CS-TM5100

速别：9速  
 齿数：13-32T 11-34T  
 颜色：银色  
 设计：全新外观设计，变速能力顺滑、稳定  
 类别：旋式飞轮



### 型号：CS-TM4000

速别：8速  
 齿数：11-23T 11-25T 11-28T 11-30T 11-32T  
 颜色：银色  
 设计：全新外观设计，变速能力顺滑、稳定



### 型号：CS-TM4100

速别：8速  
 齿数：13-28T 11-32T 11-34T  
 颜色：银色  
 设计：全新外观设计，变速能力顺滑、稳定  
 安装：旋式飞轮







## 公路飞轮

### 型号: CS-TM5000

速别: 9速  
 齿数: 11-32T、11-36T、11-40T、11-42T、11-46T、11-50T  
 颜色: 银色  
 设计: 全新外观设计, 变速能力顺滑、稳定



### 型号: CS-TM5100

速别: 9速  
 齿数: 13-32T、11-34T  
 颜色: 银色  
 设计: 全新外观设计, 变速能力顺滑、稳定  
 类别: 旋式飞轮



### 型号: CS-TM4000

速别: 8速  
 齿数: 11-23T、11-25T、11-28T、11-30T、11-32T  
 颜色: 银色  
 设计: 全新外观设计, 变速能力顺滑、稳定



### 型号: CS-TM4100

速别: 8速  
 齿数: 13-28T、11-32T、11-34T  
 颜色: 银色  
 设计: 全新外观设计, 变速能力顺滑、稳定  
 安装: 旋式飞轮



## 链条

### CN-TS9000

材质: 碳素钢  
 速别: 13S  
 颜色: 银色/炫彩



### CN-TS8000

材质: 碳素钢  
 速别: 12S  
 颜色: 银色/炫彩



### CN-TS7000

材质: 碳素钢  
 速别: 11S  
 颜色: 银色/炫彩







链条

## 链条

### CN-TS6000

材质：碳素钢  
速别：10S  
颜色：银色/炫彩



### CN-TS5000

材质：碳素钢  
速别：9S  
颜色：银色/炫彩



### CN-TS4000

材质：碳素钢  
速别：8S  
颜色：银色/炫彩



CRANK SET

E-BIKE PART

BELT PULLEY

NEW GB

DERAILLEUR

ED5

## 链条

### CN-TS3000

材质：碳素钢  
速别：7S  
颜色：银色/炫彩



### CN-TS2000

材质：碳素钢  
速别：6S  
颜色：银色/炫彩



### CN-T1

材质：碳素钢  
速别：1S  
颜色：银色/炫彩







EDS



CRANK SET

E-BIKE PART

BELT PULLEY

NEW GB

DERAILLEUR

EDS

## 无线电子变速系统

## ELECTRONIC DERAILLEUR SYSTEM

### WIRELESS TRANSMISSION SYSTEM 无线变速控制系统

支持以下系统

SUPPORT THE FOLLOWING SYSTEMS

ROAD 1X11speed

MTB 1X11speed

1X12speed

USE APP

**无线控制让一切从简。**

Wireless control makes everything easy.

**支持远程软件升级，让变速器永远最新。**

Support remote software updates, so that the transmission is always up to date.

**多种信号输出，高效稳定。**

Multiple signal output, efficient and stable.

**提供更大的齿数范围，最大支持52T，最小支持10T。**

Provide a larger range of teeth, maximum support 52T, minimum support 10T.

**Ip67级防水，无惧风雨。**

Ip67 class waterproof, fearless of wind and rain.